

Village of Lakewood
VILLAGE BOARD MEETING
AGENDA

Tuesday, May 23, 2017

7:00 p.m.

RedTail Golf Club, 7900 RedTail Drive, Village of Lakewood, IL

Please Note: This meeting is being audio recorded

Roll Call - Establish Quorum

Pledge of Allegiance to the Flag

Public Comments (Not to exceed 30 minutes as an item)

The Public is invited to make an issue-oriented comment on any matter of public concern. The Public Comment may be no longer than 3 minutes in duration. Interrogation of the Village Staff, Village President, Village Board or any of their comments will not be allowed at this time. Photography taken of the Village Board or other public body shall be done from a distance of at least twelve feet from each member of the Board or public body.

CONSENT AGENDA:

Note: Items under the Consent Agenda are considered and enacted on a single motion. There is no separate discussion of these items prior to the Board vote unless: 1) a Board Member requests that an item be removed from the Consent Agenda for separate action or 2) a citizen requests an item be removed and this request is, in turn, proposed by a member of the Village Board for separate action.

1. Request Approval of Minutes:
 - a. May 9, 2017 Regular Village Board Meeting
2. Request Approval of Bill Lists:
 - a. Accounts Payable Dated April 30, 2017 in the Amount of \$48,743.25
 - b. Accounts Payable Dated May 24, 2017 in the Amount of \$345,061.05
3. Request Approval of Financial Statements: None
4. Items Removed from Consent Agenda - If Any

AGENDA ITEMS FOR DISCUSSION

5. Motion to Approve Ordinance No. 2017-(16) – An Ordinance Granting Variances from Sections 7.2B, 7.4A, and 7.4B of the Zoning Ordinance of the Village of Lakewood Relative to Accessory Structures and Masonry Privacy Wall for 8680 Belfield Road
6. Motion to Approve Ordinance No. 2017-(17) – An Ordinance Authorizing the Sale or Disposal of Personal Property Owned by the Village of Lakewood
7. Motion to Approve the Purchase of the 2018 International Series 7400 SBA 4x2 Truck in the Amount of \$177,428 from Rush Truck Centers
8. Motion to Approve an Agreement with Eder, Casella & Co. to Perform the Village of Lakewood’s Audit Examination and Preparation of the Annual Financial Report for the State of Illinois for Fiscal Year Ending April 30, 2017
9. Reports and Comments: (To Begin No Later than 10:15 p.m.)
 - a. Village Clerk
 - b. Village Treasurer
 - c. Deputy Village Manager
 - d. Village Attorney
 - e. Village President
 - f. Village Trustees
10. Other Business
11. Executive Session –
Closed Meetings: The Village Board may hold a closed meeting to consider, among other items, the following under the Illinois Open Meetings Act: 1) the appointment, employment, compensation, discipline, performance, or dismissal of specific employees of the Village, including hearing testimony on a complaint lodged against an employee to determine its validity; 2) collective negotiating matters between the Village and its employees or their representatives, or deliberations concerning salary schedules for one or more classes of employees; 3) the purchase or lease of real property for the use of the Village; including meetings held for the purpose of discussing whether a particular parcel should be acquired; and 4) litigation, when an action against, affecting or on behalf of the Village has been filed and pending before a court or administrative tribunal, or when the Village finds that an action is probable or imminent, in which case the basis for the finding shall be recorded and entered into the minutes of the closed meeting.
12. Reports and/or Actions from Executive Session
13. New Business

14. Adjournment (NO LATER THAN 10:30 P.M.)

The Village of Lakewood is subject to the requirements of the Americans with Disabilities Act of 1990. Individuals with disabilities who plan to attend this Meeting and who require certain accommodations so that they can observe and/or participate in this Meeting, or who have questions regarding the accessibility of the Meeting or the Village's facilities, should contact the Village's ADA Coordinator at (815-459-3025) promptly to allow the Village to make reasonable accommodations for those persons.

**VILLAGE OF LAKEWOOD
MINUTES OF THE VILLAGE BOARD MEETING
MAY 9, 2017**

The Village Board Meeting was called to order at 7:03 p.m. at RedTail Golf Club by President Smith. Present were Trustees Davis, Furey, McMahon, Serwatka, and Thomas. Trustee Iden was absent. Also present were Deputy Village Manager Shannon Andrews; Village Clerk Janice Hansen; Village Attorney Michael Smoron; Chief of Police Leigh Rawson; and many members of the public.

OATHS OF OFFICE WERE ADMINISTERED BY ATTORNEY SMORON TO PRESIDENT SERWATKA; AND TRUSTEES RITCHIE AND STEPHAN

PUBLIC COMMENTS: Cheryl Nix of 8005 RedTail Drive thanked the newly elected officials on behalf of the Village residents.

CONSENT AGENDA: The following were considered and enacted on a single motion by Trustee McMahon, seconded by Trustee Davis:

APPROVAL OF MINUTES: April 25, 2017 Planning and Zoning Committee and April 25, 2017 Regular Village Board Meeting

APPROVAL OF BILL LISTS: Accounts Payable Dated April 30, 2017 in the Amount of \$14,100.76; Accounts Payable Pre-Paid Invoices for April, 2017 in the Amount of \$2,214.59; and Accounts Payable Invoices Dated April 30, 2017 in the Amount of \$20,455.97

APPROVAL OF FINANCIAL STATEMENTS: None

APPROVAL OF A SPECIAL EVENT PERMIT BY SCHOOL DISTRICT 155 FOR A BASS FISHING INVITATIONAL TOURNAMENT ON JUNE 7, 2017 FROM 6:25 A.M. TO 12:30 P.M. ON CRYSTAL LAKE

Voting Aye: Trustees Davis, McMahon, Ritchie, and Stephan. Voting Nay: None. Motion declared carried.

ITEMS REMOVED FROM THE CONSENT AGENDA: None

APPROVAL OF A RESOLUTION HONORING PAST PRESIDENT MARY ERIN SMITH: Trustee Davis read a Resolution Honoring Past President Mary Erin Smith and presented her with a clock memorializing her services.

Trustee Davis, seconded by Trustee McMahon, moved to approve a Resolution Honoring Past President Mary Erin Smith. Voting Aye: Trustees Davis, McMahon, Ritchie, and Stephan. Voting Nay: None. Motion declared carried.

APPROVAL OF APPOINTMENTS OF JOHN O'HARA THROUGH APRIL 30, 2020 AND ANDY KNAPP THROUGH APRIL 30, 2018 TO THE PLANNING AND ZONING COMMISSION: President Serwatka commented that he has had many discussions with these individuals and believes they will bring a new level of expertise and professionalism to the Commission.

Trustee Davis commented that he is the last remaining member of the Planning and Zoning Committee and he believes that this Committee's duties should be reassigned to the Planning and Zoning Commission.

Trustee Stephan, seconded by Trustee Ritchie, moved to approve the appointments of John O'Hara through April 30, 2020 and Andy Knapp through April 30, 2018 to the Planning and Zoning Commission. Voting Aye: Trustees Davis, McMahon, Ritchie, and Stephan. Voting Nay: None. Motion declared carried.

APPROVAL OF THE APPOINTMENT OF JOHN O'HARA AS CHAIRMAN FOR THE PLANNING AND ZONING COMMISSION:

Trustee McMahon, seconded by Trustee Ritchie, moved to approve the appointment of John O'Hara as Chairman for the Planning and Zoning Commission. Voting Aye: Trustees Davis, McMahon, Ritchie, and Stephan. Voting Nay: None. Motion declared carried.

APPROVAL OF THE PURCHASE OF THE IN-CAR VIDEO CAMERAS IN THE AMOUNT OF \$24,180 FROM WATCH GUARD FOR THE VILLAGE POLICE DEPARTMENT: Deputy Village Manager Shannon Andrews commented that the current squad car video cameras are over ten years old and the Police Department has been notified by Watch Guard that our system has reached the end of service eligibility and will no longer be supported. The new in-car video camera system will eliminate personnel time to manage the system as the video will automatically download to a secure cloud-based record storage and FOIA responses can be handled via computer, no more DVDs. Should body cameras be incorporated in the future, they will be compatible with the new squad car video system.

There was general discussion regarding Watch Guards capabilities; 180 degree visual, contract includes annual maintenance, and video is uploaded automatically.

Trustee Davis, seconded by Trustee Ritchie, moved to approve the purchase of the in-car video cameras in the amount of \$24,180 from Watch Guard for the Village Police Department. Voting Aye: Trustees Davis, Odom, McMahon, Ritchie, and Stephan. Voting Nay: None. Motion declared carried.

APPROVAL OF THE PURCHASE OF THE 2018 INTERNATIONAL SERIES 7400 SBA 4X2 TRUCK IN THE AMOUNT OF \$177,428 FROM RUSH TRUCK CENTERS: President Serwatka commented that this agenda item was tabled at the last Board Meeting so an informal committee of residents and staff could discuss this item. The informal committee has not been coordinated to date. Individual residents have met with staff to share ideas, such as leasing equipment within Public Works. As an alternate to purchase, staff secured a five year lease proposal from Rush Truck Centers with annual payments of \$39,208.01 for a total cost of the vehicle of \$196,040.05 which exceeds the purchase price by \$18,612.05.

Trustees Ritchie and Stephan were uncomfortable moving forward with this agenda item without additional information from the proposed Public Works Committee experts. Trustee McMahon expressed concern with postponing ordering the truck which could delay delivery and cause added expenses to the maintenance of the existing old truck. Trustee Davis felt that Public Works Foreman Barry Wickersheim was doing an excellent job. The majority needed more information to proceed with this agenda item.

Trustee Ritchie, seconded by Trustee Stephan, moved to table the purchase the 2018 International Series 7400 SBA 4X2 truck in the amount of \$177,428 from Rush Truck Centers until the May 23, 2017 Board Meeting where a vote will be taken. Voting Aye: Trustees Davis, Ritchie, and Stephan. Voting Nay: Trustee McMahon. Motion declared carried.

APPROVAL OF ORDINANCE NO. 2017-14 – AN ORDINANCE APPROVE A FIVE (5) YEAR LEASE AGREEMENT WITH RUSH TRUCK CENTERS FRO THE 2018 INTERNATIONAL SERIES 7400 SBA 4X2 TRUCK: This Agenda Item was not considered.

APPROVAL OF AN AGREEMENT FOR FINANCE DIRECTOR SERVICES WITH HARRY SAKAI: Deputy Village Manager Shannon Andrews commented that this Agreement includes an hourly rate of \$75 with an anticipated workload of approximately ten hours per week and a maximum of \$4,800 per month. Mr. Sakai will serve as Treasurer which receives an additional \$100 per month according to the Village's Municipal Code. Mr. Sakai will serve as Finance Director/Treasurer until a full time candidate can be secured.

Trustee Ritchie, seconded by Trustee Stephan, moved to approve an agreement for Finance Director services with Harry Sakai. Voting Aye: Trustees Davis, McMahon, Ritchie, and Stephan. Voting Nay: None. Motion declared carried.

APPROVAL OF THE APPOINTMENT OF VILLAGE TREASURER TO HARRY SAKAI FOR A TERM OF 12 WEEKS:

Trustee Ritchie, seconded by Trustee Davis, moved for the approval of the appointment of Village Treasurer to Harry Sakai for a term of 12 weeks. Voting Aye: Trustees Davis, McMahon, Ritchie, and Stephan. Voting Nay: None. Motion declared carried.

REPORTS: Deputy Village Manager Shannon Andrews commented that she is going to send out a letter to the east side residents requesting them to have their homes inspected for proper plumbing connections to the Village sewer system.

President Serwatka thanked the public at the Meeting for their patience during his first Board Meeting as President.

Trustee Stephan thanked the residents for their support during the election.

With nothing further to discuss, Trustee Davis, seconded by Trustee Ritchie, moved to adjourn the meeting. Voting Aye: Trustees Davis, McMahon, Ritchie, and Stephan. Voting Nay: None. Motion declared carried. The meeting adjourned at 8:01 p.m.

Janice S. Hansen
Village Clerk

Approved: _____

Dated: May 23, 2017

Village of Lakewood

Accounts Payable
April 30, 2017

Summary by Fund and Department

<u>Fund</u>	<u>Department</u>	<u>Amount</u>
10 General Fund		
	10 Administration	\$2,883.31
	15 Police	\$2,800.00
	20 Planning & Zoning	\$1,058.10
	21 Public Works	\$32,868.12
	24 Building	\$1,950.00
	Fund Total	\$41,559.53
60 Lakewood Utilities		\$437.50
	25 Water	\$112.50
	28 Sewer	\$330.62
	Fund Total	\$880.62
62 Lakewood Utilities Capital Improvements		\$542.50
72 SSA #8		\$230.38
92 Lake Patrol		\$250.00
94 RedTail Golf Club		\$2,029.00
	40 Course Maintenance	\$1,768.73
	45 General & Administration	\$200.48
	Fund Total	\$3,998.21
95 Agency Fund		\$1,282.01
	Total All Funds	\$48,743.25

Baxter and Woodman: \$35,202.39

INVOICE APPROVAL LIST REPORT - DETAIL WITH GL DIST

April 30, 2017

Date: 05/17/2017

Time: 1:54 pm

Page: 1

VILLAGE OF LAKEWOOD

Vendor Name	Invoice Description 1	Ref No.	Discount Date	
Vendor Name Line 2	Invoice Description 2	PO No.	Pay Date	
Vendor Address	Vendor Number	Check No.	Due Date	Taxes Withheld
City	Bank	Check No.	Check Date	Discount Amount
State/Province Zip/Postal	Invoice Number			Check Amount

BAXTER & WOODMAN, INC.	Cambria Lots 3-6 Utility Modif	47990	05/05/2017	
			04/30/2017	
PO BOX 6192	BAXWOO		05/05/2017	0.00
CAROL STREAM	HSB	0	00/00/0000	0.00
IL 60197-6192	0192273			75.00

GL Number	Description	Invoice Amount	Amount Relieved
95-00-2485.000	Developer Deposits	75.00	0.00

BAXTER & WOODMAN, INC.	SLPR 2017-8820 Belfield	47991	05/05/2017	
			04/30/2017	
PO BOX 6192	BAXWOO		05/05/2017	0.00
CAROL STREAM	HSB	0	00/00/0000	0.00
IL 60197-6192	0192292			650.00

GL Number	Description	Invoice Amount	Amount Relieved
10-24-8435.035	Engineering-Stormwater Manage	650.00	0.00

BAXTER & WOODMAN, INC.	SLPR 2017- 6824 Cambria Cove	47992	05/05/2017	
			04/30/2017	
PO BOX 6192	BAXWOO		05/05/2017	0.00
CAROL STREAM	HSB	0	00/00/0000	0.00
IL 60197-6192	0192290			650.00

GL Number	Description	Invoice Amount	Amount Relieved
10-24-8435.035	Engineering-Stormwater Manage	650.00	0.00

BAXTER & WOODMAN, INC.	SLPR 2017- 6950 Cambria Cove	47993	05/05/2017	
			04/30/2017	
PO BOX 6192	BAXWOO		05/05/2017	0.00
CAROL STREAM	HSB	0	00/00/0000	0.00
IL 60197-6192	0192291			650.00

GL Number	Description	Invoice Amount	Amount Relieved
10-24-8435.035	Engineering-Stormwater Manage	650.00	0.00

BAXTER & WOODMAN, INC.	Lake Ave STP Construction Serv	47994	05/05/2017	
			04/30/2017	
PO BOX 6192	BAXWOO		05/05/2017	0.00
CAROL STREAM	HSB	0	00/00/0000	0.00
IL 60197-6192	0192276			29,593.64

GL Number	Description	Invoice Amount	Amount Relieved
10-21-8435.000	Engineering Services	29,593.64	0.00

BAXTER & WOODMAN, INC.	General Eng. FY2017	47998	05/05/2017	
			04/30/2017	
PO BOX 6192	BAXWOO		05/05/2017	0.00
CAROL STREAM	HSB	0	00/00/0000	0.00
IL 60197-6192	0192285			1,640.00

GL Number	Description	Invoice Amount	Amount Relieved
10-21-8435.000	Engineering Services	1,640.00	0.00

BAXTER & WOODMAN, INC.	Halgus Elevated Tank Repair	47999	05/05/2017	
			04/30/2017	
PO BOX 6192	BAXWOO		05/05/2017	0.00
CAROL STREAM	HSB	0	00/00/0000	0.00
IL 60197-6192	0192288			542.50

GL Number	Description	Invoice Amount	Amount Relieved
62-00-8435.000	Engineering Services	542.50	0.00

BAXTER & WOODMAN, INC.	Wilke Prop Spcl Use Ord Rev	48000	05/05/2017	
			04/30/2017	
PO BOX 6192	BAXWOO		05/05/2017	0.00
CAROL STREAM	HSB	0	00/00/0000	0.00
IL 60197-6192	0192289			1,401.25

GL Number	Description	Invoice Amount	Amount Relieved
-----------	-------------	----------------	-----------------

INVOICE APPROVAL LIST REPORT - DETAIL WITH GL DIST

April 30, 2017

Date: 05/17/2017

Time: 1:54 pm

Page: 2

VILLAGE OF LAKEWOOD

Vendor Name	Invoice Description1	Ref No.	Discount Date	
Vendor Name Line 2	Invoice Description2	PO No.	Pay Date	
Vendor Address	Vendor Number		Due Date	Taxes Withheld
City	Bank	Check No.	Check Date	Discount Amount
State/Province Zip/Postal	Invoice Number			Check Amount
10-21-8435.000	Engineering Services	1,401.25	0.00	

Check No.	0	Total:	35,202.39
Total for	BAXTER & WOODMAN, INC.		35,202.39

GL Number	Description	Invoice Amount	Amount Relieved
92-00-8416.000	Equipment O/M/R	250.00	0.00

Check No.	0	Total:	250.00
Total for	CAPTAIN ROD'S - BRR INC.		250.00

GL Number	Description	Invoice Amount	Amount Relieved
94-40-8170.000	Physicals/Drug Testing	30.00	0.00

Check No.	0	Total:	30.00
Total for	CENTEGRA OCCUPATIONAL HEAL		30.00

GL Number	Description	Invoice Amount	Amount Relieved
72-00-8439.000	Electricity	167.78	0.00

Check No.	0	Total:	0.00
Total for	COMED		0.00

GL Number	Description	Invoice Amount	Amount Relieved
60-28-8439.000	Electricity	262.70	0.00

Check No.	0	Total:	0.00
Total for	COMED		0.00

GL Number	Description	Invoice Amount	Amount Relieved
60-28-8439.000	Electricity	67.92	0.00

Check No.	0	Total:	0.00
Total for	COMED		0.00

INVOICE APPROVAL LIST REPORT - DETAIL WITH GL DIST

April 30, 2017

Date: 05/17/2017

Time: 1:54 pm

Page: 3

VILLAGE OF LAKEWOOD

Vendor Name	Invoice Description1	Ref No.	Discount Date	
Vendor Name Line 2	Invoice Description2	PO No.	Pay Date	
Vendor Address	Vendor Number		Due Date	Taxes Withheld
City	Bank	Check No.	Check Date	Discount Amount
State/Province Zip/Postal	Invoice Number			Check Amount

GL Number	Description	Invoice Amount	Amount Relieved	
72-00-8439.000	Electricity	31.30	0.00	
COMED	Trnbry Aerator Act3128680001	48017	05/12/2017	
			04/30/2017	
PO BOX 6111	COMED		05/12/2017	0.00
CAROL STREAM	HSB	0	00/00/0000	0.00
IL 60197-6111	051217			31.30

GL Number	Description	Invoice Amount	Amount Relieved	
72-00-8439.000	Electricity	31.30	0.00	
COMED	Muirfield Pump Act3128608009	48018	05/10/2017	
			04/30/2017	
PO BOX 6111	COMED		05/10/2017	0.00
CAROL STREAM	HSB	0	00/00/0000	0.00
IL 60197-6111	051017B			90.48

GL Number	Description	Invoice Amount	Amount Relieved	
94-40-8439.000	Electricity	90.48	0.00	
		Check No. 0	Total:	651.48
		Total for COMED		651.48

GOLFNOW G1, LLC	Card Swipe	47997	04/28/2017	
			04/30/2017	
P.O BOX 742569	GOLFNOW		04/28/2017	0.00
ATLANTA	HSB	0	00/00/0000	0.00
GA 30374-2569	5100129548			156.73

GL Number	Description	Invoice Amount	Amount Relieved	
94-45-8416.000	Equipment O/M/R	156.73	0.00	
		Check No. 0	Total:	156.73
		Total for GOLFNOW G1, LLC		156.73

ILLINOIS DEPARTMENT OF REVENUE	Sales Tax- April	47995	04/30/2017	
			04/30/2017	
RETAILERS OCCUPATION TAX	ILLREV		04/30/2017	0.00
SPRINGFIELD	HSB	0	00/00/0000	0.00
IL 62796-0001	050117			2,029.00

GL Number	Description	Invoice Amount	Amount Relieved	
94-00-2208.000	Sales Tax Payable	2,029.00	0.00	
		Check No. 0	Total:	2,029.00
		Total for ILLINOIS DEPARTMENT OF REVEI		2,029.00

MCHENRY ANALYTICAL WATER LABORATORY, INC.	Samples	48004	04/27/2017	
			04/30/2017	
4314-A Crystal Lake Road	MCHANA		04/27/2017	0.00
McHenry	HSB	0	00/00/0000	0.00
IL 60050-4208	1702155			112.50

GL Number	Description	Invoice Amount	Amount Relieved	
60-25-8444.000	Water Testing Service	112.50	0.00	
		Check No. 0	Total:	112.50
		Total for MCHENRY ANALYTICAL WATER		112.50

INVOICE APPROVAL LIST REPORT - DETAIL WITH GL DIST

April 30, 2017

Date: 05/17/2017

Time: 1:54 pm

Page: 4

VILLAGE OF LAKEWOOD

Vendor Name	Invoice Description1	Ref No.	Discount Date	
Vendor Name Line 2	Invoice Description2	PO No.	Pay Date	
Vendor Address	Vendor Number	Check No.	Due Date	Taxes Withheld
City	Bank	Check No.	Check Date	Discount Amount
State/Province Zip/Postal	Invoice Number			Check Amount

NICOR GAS	Gas Lights	48002	05/03/2017	
			04/30/2017	
PO BOX 5407	NICOR		05/03/2017	0.00
CAROL STREAM	HSB	0	00/00/0000	0.00
IL 60197-5407	050317A			199.54

GL Number	Description	Invoice Amount	Amount Relieved
10-21-8212.000	Street Lights M/R Supplies	199.54	0.00

NICOR GAS	Gas Lights	48003	05/03/2017	
			04/30/2017	
PO BOX 5407	NICOR		05/03/2017	0.00
CAROL STREAM	HSB	0	00/00/0000	0.00
IL 60197-5407	050317B			33.69

GL Number	Description	Invoice Amount	Amount Relieved
10-21-8212.000	Street Lights M/R Supplies	33.69	0.00

Check No.	0	Total:	233.23
Total for	NICOR GAS		233.23

REINDERS	Pivot Weldment	48010	02/28/2017	
			04/30/2017	
PO BOX 78955	REINDERS		02/28/2017	0.00
MILWAUKEE	HSB	0	00/00/0000	0.00
WI 53278-0955	1672612			187.47

GL Number	Description	Invoice Amount	Amount Relieved
94-40-8416.000	Equipment O/M/R	187.47	0.00

REINDERS	Towels, Flags	48019	05/01/2017	
			04/30/2017	
PO BOX 78955	REINDERS		05/01/2017	0.00
MILWAUKEE	HSB	0	00/00/0000	0.00
WI 53278-0955	4245811			905.60

GL Number	Description	Invoice Amount	Amount Relieved
94-40-8305.000	Other, Maintenance Supplies	905.60	0.00

Check No.	0	Total:	1,093.07
Total for	REINDERS		1,093.07

SITE ONE LANDSCAPE	Keys	48013	04/26/2017	
			04/30/2017	
24110 NETWORK PLACE	SITONE		04/26/2017	0.00
CHICAGO	HSB	0	00/00/0000	0.00
IL 60673-1241	80155962			65.18

GL Number	Description	Invoice Amount	Amount Relieved
94-40-8416.000	Equipment O/M/R	65.18	0.00

Check No.	0	Total:	65.18
Total for	SITE ONE LANDSCAPE		65.18

TURNBERRY COUNTRY CLUB	Feb & March Board Meetings	48008	04/30/2017	
			04/30/2017	
9600 Turnberry Trail	TURCOU		04/30/2017	0.00
Vlg of Lakewood	HSB	0	00/00/0000	0.00
IL 60014	5817			500.00

INVOICE APPROVAL LIST REPORT - DETAIL WITH GL DIST

April 30, 2017

Date: 05/17/2017

Time: 1:54 pm

Page: 5

VILLAGE OF LAKEWOOD

Vendor Name	Invoice Description1	Ref No.	Discount Date	
Vendor Name Line 2	Invoice Description2	PO No.	Pay Date	
Vendor Address	Vendor Number		Due Date	Taxes Withheld
City	Bank	Check No.	Check Date	Discount Amount
State/Province Zip/Postal	Invoice Number			Check Amount

GL Number	Description	Invoice Amount	Amount Relieved
10-10-8490.000	Contractual Services - NEC	500.00	0.00
		Check No. 0	Total: 500.00
		Total for	TURNBERRY COUNTRY CLUB 500.00

STEVE UNRUH	Consulting Services 3/12-4/29	47996	04/30/2017	
1121 SAWMILL LANE	UNRSTE		04/30/2017	0.00
ALGONQUIN	HSB	0	00/00/0000	0.00
IL 60102	43017			490.00

GL Number	Description	Invoice Amount	Amount Relieved
94-40-8490.000	Contractual Services - NEC	490.00	0.00
		Check No. 0	Total: 490.00
		Total for	STEVE UNRUH 490.00

WAGE WORKS	Cobra Fee	48007	04/30/2017	
PO BOX 8363	WAGWOR		04/30/2017	0.00
PASADENA	HSB	0	00/00/0000	0.00
CA 91109-8363	0417--TR42093			38.00

GL Number	Description	Invoice Amount	Amount Relieved
10-10-8175.000	Employee Programs	38.00	0.00
		Check No. 0	Total: 38.00
		Total for	WAGE WORKS 38.00

ZUKOWSKI, ROGERS, FLOOD & MCARDLE	Attorney Fees 3/16-4/18	48001	05/04/2017	
50 VIRGINIA STREET	ZUKROG		04/30/2017	0.00
CRYSTAL LAKE	HSB	0	00/00/0000	0.00
IL 60014	125078			236.25

GL Number	Description	Invoice Amount	Amount Relieved	
10-10-8450.000	Legal Fees	236.25	0.00	
ZUKOWSKI, ROGERS, FLOOD & MCARDLE	Beto Varance	48005	04/18/2017	
50 VIRGINIA STREET	ZUKROG		04/30/2017	0.00
CRYSTAL LAKE	HSB	0	00/00/0000	0.00
IL 60014	125090			1,207.01

GL Number	Description	Invoice Amount	Amount Relieved	
95-00-2485.000	Developer Deposits	1,207.01	0.00	
ZUKOWSKI, ROGERS, FLOOD & MCARDLE	Genl Legal April	48012	05/09/2017	
50 VIRGINIA STREET	ZUKROG		04/30/2017	0.00
CRYSTAL LAKE	HSB	0	00/00/0000	0.00
IL 60014	125580			6,448.41

GL Number	Description	Invoice Amount	Amount Relieved
10-10-8450.000	Legal Fees	2,109.06	0.00
10-15-8450.000	Legal Fees	2,800.00	0.00
10-20-8450.000	Legal Fees	1,058.10	0.00
60-00-8450.000	Legal Fees	437.50	0.00
94-45-8461.000	Legal & Audit	43.75	0.00

INVOICE APPROVAL LIST REPORT - DETAIL WITH GL DIST

April 30, 2017

Date: 05/17/2017

Time: 1:54 pm

Page: 6

VILLAGE OF LAKEWOOD

Vendor Name	Invoice Description1	Ref No.	Discount Date	
Vendor Name Line 2	Invoice Description2	PO No.	Pay Date	
Vendor Address	Vendor Number		Due Date	Taxes Withheld
City	Bank	Check No.	Check Date	Discount Amount
State/Province Zip/Postal	Invoice Number			Check Amount

Check No.	0	Total:	7,891.67
Total for	ZUKOWSKI, ROGERS, FLOOD &		7,891.67

Total Invoices: 30

Grand Total:	48,743.25
Less Credit Memos:	0.00
Net Total:	48,743.25
Less Hand Check Total:	0.00
Outstanding Invoice Total:	48,743.25

INVOICE APPROVAL LIST BY FUND
April 30, 2017

Date: 05/17/2017
Time: 1:55pm
Page: 1

VILLAGE OF LAKEWOOD

Fund	GL Number	Vendor Name	Check	Invoice	Due	Amount
Department	Abbrev	Invoice Description	Number	Number	Date	
Account						
Fund: General Fund						
Dept: Administration						
10-10-8175.000	Employee P	WAGE WORKS Cobra Fee	0	0417--TR42093	04/30/2017	38.00
10-10-8450.000	Legal Fees	ZUKOWSKI, ROGERS, FLOOD & Attorney Fees 3/16-4/18	0	125078	05/04/2017	236.25
10-10-8450.000	Legal Fees	ZUKOWSKI, ROGERS, FLOOD & Genl Legal April	0	125580	05/09/2017	2,109.06
10-10-8490.000	Contractua	TURNBERRY COUNTRY CLUB Feb & March Board Meetings	0	5817	04/30/2017	500.00
Total Administration						2,883.31
Dept: Police Department						
10-15-8450.000	Legal Fees	ZUKOWSKI, ROGERS, FLOOD & Genl Legal April	0	125580	05/09/2017	2,800.00
Total Police Department						2,800.00
Dept: Planning & Zoning Department						
10-20-8450.000	Legal Fees	ZUKOWSKI, ROGERS, FLOOD & Genl Legal April	0	125580	05/09/2017	1,058.10
Total Planning & Zoning Department						1,058.10
Dept: Public Works Department						
10-21-8212.000	Street Lig	NICOR GAS Gas Lights	0	050317A	05/03/2017	199.54
10-21-8212.000	Street Lig	NICOR GAS Gas Lights	0	050317B	05/03/2017	33.69
10-21-8435.000	Engineerin	BAXTER & WOODMAN, INC. Lake Ave STP Construction Serv	0	0192276	05/05/2017	29,593.64
10-21-8435.000	Engineerin	BAXTER & WOODMAN, INC. General Eng. FY2017	0	0192285	05/05/2017	1,640.00
10-21-8435.000	Engineerin	BAXTER & WOODMAN, INC. Wilke Prop Spcl Use Ord Rev	0	0192289	05/05/2017	1,401.25
Total Public Works Department						32,868.12
Dept: Building Department						
10-24-8435.035	Engineerin	BAXTER & WOODMAN, INC. SLPR 2017-8820 Belfield	0	0192292	05/05/2017	650.00
10-24-8435.035	Engineerin	BAXTER & WOODMAN, INC. SLPR 2017- 6824 Cambria Cove	0	0192290	05/05/2017	650.00
10-24-8435.035	Engineerin	BAXTER & WOODMAN, INC. SLPR 2017- 6950 Cambria Cove	0	0192291	05/05/2017	650.00
Total Building Department						1,950.00
Fund Total						41,559.53
Fund: Lakewood Utilities						
Dept: Non-Department						
60-00-8450.000	Legal Fees	ZUKOWSKI, ROGERS, FLOOD & Genl Legal April	0	125580	05/09/2017	437.50
Total Non-Department						437.50
Dept: Water Department						
60-25-8444.000	Water Test	MCHENRY ANALYTICAL WATER Samples	0	1702155	04/27/2017	112.50
Total Water Department						112.50
Dept: Sewer Department						
60-28-8439.000	Electricit	COMED Broadway Lift Act3123071182	0	051017A	05/10/2017	262.70
60-28-8439.000	Electricit	COMED Ballard Lift Act 0180149017	0	051117	05/11/2017	67.92
Total Sewer Department						330.62
Fund Total						880.62
Fund: LWU Capital Improvements						
Dept: Non-Department						
62-00-8435.000	Engineerin	BAXTER & WOODMAN, INC. Haligus Elevated Tank Repaint	0	0192288	05/05/2017	542.50

INVOICE APPROVAL LIST BY FUND
April 30, 2017

Date: 05/17/2017
Time: 1:55pm
Page: 2

VILLAGE OF LAKEWOOD

Fund	Department	Account	GL Number Abbrev	Vendor Name Invoice Description	Check Number	Invoice Number	Due Date	Amount
Fund: LNU Capital Improvements								
Dept: Non-Department								

Total Non-Department								542.50

Fund Total								542.50
Fund: Special Service Area #8								
Dept: Non-Department								
72-00-8439.000	Electricit	COMED		Turnberry Aerator Act118717108	0	050817	05/08/2017	167.78
72-00-8439.000	Electricit	COMED		Bonnie Aerator Act1466128040	0	050917	05/09/2017	31.30
72-00-8439.000	Electricit	COMED		Trnbry Aerator Act3128680001	0	051217	05/12/2017	31.30

Total Non-Department								230.38

Fund Total								230.38
Fund: Lake Patrol Fund								
Dept: Non-Department								
92-00-8416.000	Equipment	CAPTAIN ROD'S - BRR INC.		Install Lift & Pier	0	32017A	03/20/2017	250.00

Total Non-Department								250.00

Fund Total								250.00
Fund: Golf Course Fund								
Dept: Non-Department								
94-00-2208.000	Sales Tax	ILLINOIS DEPARTMENT OF REVENUE		Sales Tax- April	0	050117	04/30/2017	2,029.00

Total Non-Department								2,029.00
Dept: Course Maintenance Department								
94-40-8170.000	Physicals/	CENTEGRA OCCUPATIONAL HEALTH		Pre Employ (1EE)	0	189822	04/30/2017	30.00
94-40-8305.000	Other, Mai	REINDERS		Towels, Flags	0	4245811	05/01/2017	905.60
94-40-8416.000	Equipment	REINDERS		Pivot Weldment	0	1672612	02/28/2017	187.47
94-40-8416.000	Equipment	SITE ONE LANDSCAPE		Keys	0	80155962	04/26/2017	65.18
94-40-8439.000	Electricit	COMED		Muirfield Pump Act3128608009	0	051017B	05/10/2017	90.48
94-40-8490.000	Contractua	STEVE UNRUH		Consulting Services 3/12-4/29	0	43017	04/30/2017	490.00

Total Course Maintenance Department								1,768.73
Dept: General & Administrative Dept								
94-45-8416.000	Equipment	GOLFNOW G1, LLC		Card Swipe	0	5100129548	04/28/2017	156.73
94-45-8461.000	Legal & Au	ZUKOWSKI, ROGERS, FLOOD &		Genl Legal April	0	125580	05/09/2017	43.75

Total General & Administrative Dept								200.48

Fund Total								3,998.21
Fund: Agency Fund								
Dept: Non-Department								
95-00-2485.000	Developer	BAXTER & WOODMAN, INC.		Cambria Lots 3-6 Utility Modif	0	0192273	05/05/2017	75.00
95-00-2485.000	Developer	ZUKOWSKI, ROGERS, FLOOD &		Beto Variance	0	125090	04/18/2017	1,207.01

Total Non-Department								1,282.01

Fund Total								1,282.01

Grand Total								48,743.25

Village of Lakewood

Accounts Payable
May 24, 2017

Summary by Fund and Department

<u>Fund</u>	<u>Department</u>	<u>Amount</u>
10 General Fund		\$10,976.22
	10 Administration	\$1,735.11
	15 Police	\$79,765.30
	21 Public Works	\$3,870.28
	24 Building	\$121.43
	Fund Total	\$96,468.34
60 Lakewood Utilities		\$188,984.36
	25 Water	\$807.00
	Fund Total	\$189,791.36
72 SSA #8		\$10,000.00
85 Refuse		\$24,362.32
92 Lake Patrol		\$270.00
94 RedTail Golf Club		\$7,680.38
	30 Pro Shop	\$4,573.59
	35 Food & Beverage	\$388.58
	40 Course Maintenance	\$8,236.31
	45 General & Administration	\$3,290.17
	Fund Total	\$24,169.03
	Total All Funds	\$345,061.05

Baxter and Woodman: \$0.00

INVOICE APPROVAL LIST REPORT - DETAIL WITH GL DIST

May 24, 2017

Date: 05/19/2017

Time: 3:06 pm

Page: 1

VILLAGE OF LAKEWOOD

Vendor Name	Invoice Description1	Ref No.	Discount Date	
Vendor Name Line 2	Invoice Description2	PO No.	Pay Date	
Vendor Address	Vendor Number		Due Date	Taxes Withheld
City	Bank	Check No.	Check Date	Discount Amount
State/Province Zip/Postal	Invoice Number			Check Amount

ACE HARDWARE	Fasteners	48109	05/03/2017	
			05/24/2017	
215 N. SPRING STREET	ACEHAR		05/03/2017	0.00
ELGIN	HSB	0	00/00/0000	0.00
IL 60120	103309			27.04

GL Number	Description	Invoice Amount	Amount Relieved
10-21-8212.000	Street Lights M/R Supplies	27.04	0.00

Check No.	0	Total:	27.04
Total for	ACE HARDWARE		27.04

ALLY	Chief's Car Lease	48055	05/11/2017	
			05/24/2017	
Payment Processing Center	ALLY		05/11/2017	0.00
PO BOX 9001951	HSB	0	00/00/0000	0.00
LOUISVILLE	051117			242.96
KY 40290-1951				

GL Number	Description	Invoice Amount	Amount Relieved
10-15-8260.000	Mileage Reimbursement	242.96	0.00

Check No.	0	Total:	242.96
Total for	ALLY		242.96

AMALGAMATED BANK OF CHICAGO	Paying Agent Fee 2010B	48078	05/01/2017	
			05/24/2017	
CORPORATE TRUST DEPT	AMABAN		05/01/2017	0.00
PO BOX 94445	HSB	0	00/00/0000	0.00
CHICAGO	050117A			475.00
IL 60690-4445				

GL Number	Description	Invoice Amount	Amount Relieved
60-00-8700.000	Paying Agent/Bond Fees	475.00	0.00

AMALGAMATED BANK OF CHICAGO	Paying Agent Fee 2010A	48079	05/01/2017	
			05/24/2017	
CORPORATE TRUST DEPT	AMABAN		05/01/2017	0.00
PO BOX 94445	HSB	0	00/00/0000	0.00
CHICAGO	050117B			475.00
IL 60690-4445				

GL Number	Description	Invoice Amount	Amount Relieved
60-00-8700.000	Paying Agent/Bond Fees	475.00	0.00

AMALGAMATED BANK OF CHICAGO	WWTP Bond Series 2010B	48080	05/01/2017	
			05/24/2017	
CORPORATE TRUST DEPT	AMABAN		05/01/2017	0.00
PO BOX 94445	HSB	0	00/00/0000	0.00
CHICAGO	050117C			131,284.38
IL 60690-4445				

GL Number	Description	Invoice Amount	Amount Relieved
60-00-8702.085	Interest Payments-2010B	131,284.38	0.00

AMALGAMATED BANK OF CHICAGO	Tower 1 Series 2010A	48081	05/01/2017	
			05/24/2017	
CORPORATE TRUST DEPT	AMABAN		05/01/2017	0.00
PO BOX 94445	HSB	0	00/00/0000	0.00
CHICAGO	050117D			50,846.75
IL 60690-4445				

GL Number	Description	Invoice Amount	Amount Relieved
60-00-8702.080	Interest Payments-2010A	50,846.75	0.00

Check No.	0	Total:	183,081.13
-----------	---	--------	------------

INVOICE APPROVAL LIST REPORT - DETAIL WITH GL DIST

May 24, 2017

Date: 05/19/2017

Time: 3:06 pm

Page: 2

VILLAGE OF LAKEWOOD

Vendor Name	Invoice Description 1	Ref No.	Discount Date	
Vendor Name Line 2	Invoice Description 2	PO No.	Pay Date	
Vendor Address	Vendor Number		Due Date	Taxes Withheld
City	Bank	Check No.	Check Date	Discount Amount
State/Province Zip/Postal	Invoice Number			Check Amount

Total for AMALGAMATED BANK OF CHICAG 183,081.13

AMERICAN PUBLIC WORKS ASSOC.	Membership Renewal	48071	05/05/2017	
			05/24/2017	
PO BOX 802296	AMPW		05/05/2017	0.00
KANSAS CITY	HSB	0	00/00/0000	0.00
MO 64180-2296	050517			320.00

GL Number	Description	Invoice Amount	Amount Relieved
10-21-8495.000	Dues & Subscriptions	320.00	0.00

Check No. 0 Total: 320.00
 Total for AMERICAN PUBLIC WORKS ASSO 320.00

ANDERSON PEST CONTROL	Pest Control- VH	48035	05/01/2017	
			05/24/2017	
PO BOX 600670	ANDPES		05/01/2017	0.00
JACKSONVILLE	HSB	0	00/00/0000	0.00
FL 32260-0670	4259214			51.36

GL Number	Description	Invoice Amount	Amount Relieved
10-21-8417.000	Grounds Maint. & Repairs	51.36	0.00

ANDERSON PEST CONTROL	Pest Management- RedTail	48102	05/01/2017	
			05/24/2017	
PO BOX 600670	ANDPES		05/01/2017	0.00
JACKSONVILLE	HSB	0	00/00/0000	0.00
FL 32260-0670	4257825			46.84

GL Number	Description	Invoice Amount	Amount Relieved
94-45-8414.000	Building Maintenance & Repairs	46.84	0.00

Check No. 0 Total: 98.20
 Total for ANDERSON PEST CONTROL 98.20

CALL ONE	Monthly Service	48077	05/15/2017	
			05/24/2017	
PO BOX 76112	CALONE		05/15/2017	0.00
CLEVELAND	HSB	0	00/00/0000	0.00
OH 44101-4755	051517			1,053.29

GL Number	Description	Invoice Amount	Amount Relieved
10-10-8440.000	Telephone	218.23	0.00
10-15-8440.000	Telephone	257.94	0.00
10-24-8440.000	Telephone	43.93	0.00
60-00-8440.000	Telephone	489.21	0.00
94-40-8440.000	Telephone	43.98	0.00

CALL ONE	Monthly Service	48090	05/15/2017	
			05/24/2017	
PO BOX 76112	CALONE		05/15/2017	0.00
CLEVELAND	HSB	0	00/00/0000	0.00
OH 44101-4755	051517B			47.92

GL Number	Description	Invoice Amount	Amount Relieved
60-00-8440.000	Telephone	47.92	0.00

Check No. 0 Total: 1,101.21
 Total for CALL ONE 1,101.21

INVOICE APPROVAL LIST REPORT - DETAIL WITH GL DIST

May 24, 2017

Date: 05/19/2017

Time: 3:06 pm

Page: 3

VILLAGE OF LAKEWOOD

Vendor Name	Invoice Description1	Ref No.	Discount Date	
Vendor Name Line 2	Invoice Description2	PO No.	Pay Date	
Vendor Address	Vendor Number	Check No.	Due Date	Taxes Withheld
City	Bank	Check Date	Check Amount	Discount Amount
State/Province Zip/Postal	Invoice Number			Check Amount

CAPTAIN ROD'S - BRR INC.	Install Bouys	48051	05/19/2017	
RODNEY SCHUH			05/24/2017	
PO BOX 1448	CAPROD		05/19/2017	0.00
MCHENRY	HSB	0	00/00/0000	0.00
IL 60051	32017B			240.00

GL Number	Description	Invoice Amount	Amount Relieved
92-00-8416.000	Equipment O/M/R	240.00	0.00

Check No.	0	Total:	240.00
Total for	CAPTAIN ROD'S - BRR INC.		240.00

CASSIDY TIRES & SERVICE	Tires	48060	04/17/2017	
			05/24/2017	
200 SOUTH CHURCH STREET	CASTIR		04/17/2017	0.00
ADDISON	HSB	0	00/00/0000	0.00
IL 60101	6053941			126.92

GL Number	Description	Invoice Amount	Amount Relieved
94-40-8416.000	Equipment O/M/R	126.92	0.00

Check No.	0	Total:	126.92
Total for	CASSIDY TIRES & SERVICE		126.92

CENTEGRA OCCUPATIONAL HEALTH	Pre Employ (1EE)	48052	05/08/2017	
			05/24/2017	
PO BOX 273	CENOC		05/08/2017	0.00
BEDFORD PARK	HSB	0	00/00/0000	0.00
IL 60499-0273	190169			30.00

GL Number	Description	Invoice Amount	Amount Relieved
94-40-8170.000	Physicals/Drug Testina	30.00	0.00

CENTEGRA OCCUPATIONAL HEALTH	Pre Employ (1 EE)	48053	05/09/2017	
			05/24/2017	
PO BOX 273	CENOC		05/09/2017	0.00
BEDFORD PARK	HSB	0	00/00/0000	0.00
IL 60499-0273	190238			30.00

GL Number	Description	Invoice Amount	Amount Relieved
92-00-8170.000	Physicals/Drug Testina	30.00	0.00

CENTEGRA OCCUPATIONAL HEALTH	Pre Employ (1 EE)	48094	05/16/2017	
			05/24/2017	
PO BOX 273	CENOC		05/16/2017	0.00
BEDFORD PARK	HSB	0	00/00/0000	0.00
IL 60499-0273	190580			30.00

GL Number	Description	Invoice Amount	Amount Relieved
94-30-8170.000	Physicals/Drug Testina	30.00	0.00

CENTEGRA OCCUPATIONAL HEALTH	Pre Employ (2 EE)	48095	05/15/2017	
			05/24/2017	
PO BOX 273	CENOC		05/15/2017	0.00
BEDFORD PARK	HSB	0	00/00/0000	0.00
IL 60499-0273	190503			60.00

GL Number	Description	Invoice Amount	Amount Relieved
10-21-8170.000	Physicals/Drug Testina	30.00	0.00
94-35-8170.000	Physicals/Drug Testina	30.00	0.00

Check No.	0	Total:	150.00
-----------	---	--------	--------

INVOICE APPROVAL LIST REPORT - DETAIL WITH GL DIST

May 24, 2017

Date: 05/19/2017

Time: 3:06 pm

Page: 4

VILLAGE OF LAKEWOOD

Vendor Name	Invoice Description1	Ref No.	Discount Date	
Vendor Name Line 2	Invoice Description2	PO No.	Pay Date	
Vendor Address	Vendor Number		Due Date	Taxes Withheld
City	Bank	Check No.	Check Date	Discount Amount
State/Province Zip/Postal	Invoice Number			Check Amount
		Total for	CENTEGRA OCCUPATIONAL HEAL	150.00

GL Number	Description	Invoice Amount	Amount Relieved
94-00-1460.000	Pro Shop Inventory	1,357.48	0.00
		Check No. 0	Total: 1,357.48
		Total for	CERTI FRESH CIGARS 1,357.48

GL Number	Description	Invoice Amount	Amount Relieved
10-15-8443.000	Fire Protection Services	63,924.14	0.00
		Check No. 0	Total: 63,924.14
		Total for	CITY OF CRYSTAL LAKE 63,924.14

GL Number	Description	Invoice Amount	Amount Relieved
94-45-8440.000	Telephone	234.65	0.00
94-45-8447.000	Cable TV	89.22	0.00
		Check No. 0	Total: 323.87
		Total for	COMCAST 323.87

GL Number	Description	Invoice Amount	Amount Relieved
10-10-8495.000	Dues & Subscriptions	499.00	0.00
		Check No. 0	Total: 499.00
		Total for	CRYSTAL LAKE CHAMBER 499.00

INVOICE APPROVAL LIST REPORT - DETAIL WITH GL DIST

May 24, 2017

Date: 05/19/2017

Time: 3:06 pm

Page: 5

VILLAGE OF LAKEWOOD

Vendor Name	Invoice Description1	Ref No.	Discount Date	
Vendor Name Line 2	Invoice Description2	PO No.	Pay Date	
Vendor Address	Vendor Number		Due Date	Taxes Withheld
City	Bank	Check No.	Check Date	Discount Amount
State/Province Zip/Postal	Invoice Number			Check Amount

CRYSTAL LAKE COUNTRY CLUB	Golf Balls	48076	05/01/2017	
			05/24/2017	
721 COUNTRY CLUB ROAD	CRYCOU		05/01/2017	0.00
CRYSTAL LAKE	HSB	0	00/00/0000	0.00
IL 60014	11			800.00

GL Number	Description	Invoice Amount	Amount Relieved
94-30-8206.000	Ranqe Supplies	800.00	0.00

Check No.	0	Total:	800.00
Total for	CRYSTAL LAKE COUNTRY CLUB		800.00

ED'S RENTAL	Dolly Rental	48107	05/17/2017	
			05/24/2017	
904 N. Front Street	EDSREN		05/17/2017	0.00
McHenry	HSB	0	00/00/0000	0.00
IL 60050	197536-2			20.00

GL Number	Description	Invoice Amount	Amount Relieved
10-21-8401.000	Rental Equipment	20.00	0.00

Check No.	0	Total:	20.00
Total for	ED'S RENTAL		20.00

ENVIRONMENTAL AQUATIC MGMT LLC	Weekly Pond Management 2017	48072	05/01/2017	
			05/24/2017	
PO BOX 7239	ENVAQU		05/01/2017	0.00
ALGONQUIN	HSB	0	00/00/0000	0.00
IL 60102	10144			10,000.00

GL Number	Description	Invoice Amount	Amount Relieved
72-00-8408.000	Lake Treatment Service	10,000.00	0.00

Check No.	0	Total:	10,000.00
Total for	ENVIRONMENTAL AQUATIC MGM'		10,000.00

FJR TREE SERVICE, INC.	Remove 6 Trees	48039	05/03/2017	
			05/24/2017	
7119 SUNSET DR	FJRTRE		05/03/2017	0.00
CRYSTAL LAKE	HSB	0	00/00/0000	0.00
IL 60014	4674			1,750.00

GL Number	Description	Invoice Amount	Amount Relieved
10-21-8418.000	Tree Maint. & Purchases	1,750.00	0.00

Check No.	0	Total:	1,750.00
Total for	FJR TREE SERVICE, INC.		1,750.00

FOX VALLEY FIRE & SAFETY	Service Extinguisher	48099	05/04/2017	
			05/24/2017	
2730 PINNACLE DRIVE	FOXFIR		05/04/2017	0.00
ELGIN	HSB	0	00/00/0000	0.00
IL 60123	IN00084764			291.05

GL Number	Description	Invoice Amount	Amount Relieved
94-45-8414.000	Building Maintenance & Repairs	291.05	0.00

INVOICE APPROVAL LIST REPORT - DETAIL WITH GL DIST

May 24, 2017

Date: 05/19/2017

Time: 3:06 pm

Page: 6

VILLAGE OF LAKEWOOD

Vendor Name	Invoice Description1	Ref No.	Discount Date	
Vendor Name Line 2	Invoice Description2	PO No.	Pay Date	
Vendor Address	Vendor Number	Check No.	Due Date	Taxes Withheld
City	Bank		Check Date	Discount Amount
State/Province Zip/Postal	Invoice Number			Check Amount

Check No.	0	Total:	291.05
Total for	FOX VALLEY FIRE & SAFETY		291.05

GESKE & SONS, INC.	1 Ton Asphalt Cold Patch	48031	05/08/2017	
			05/24/2017	
400 E. TERRA COTTA AVE.	GESKE		05/08/2017	0.00
CRYSTAL LAKE	HSB	0	00/00/0000	0.00
IL 60014	37924			145.00

GL Number	Description	Invoice Amount	Amount Relieved
10-21-8250.000	Bituminous Patch	145.00	0.00

Check No.	0	Total:	145.00
Total for	GESKE & SONS, INC.		145.00

GOLF CLUB MASTERS INC	Advertisement	48073	05/01/2017	
			05/24/2017	
10769 BROADWAY, PMB 345	GOLCLU		05/01/2017	0.00
CROWN POINT	HSB	0	00/00/0000	0.00
IN 46307	050117			497.50

GL Number	Description	Invoice Amount	Amount Relieved
94-45-8456.000	Advertisina	497.50	0.00

Check No.	0	Total:	497.50
Total for	GOLF CLUB MASTERS INC		497.50

GOLF INVITE, INC	Golf Ball Launcher Rental	48100	05/19/2017	
			05/24/2017	
3925 75TH ST	GOLINV		05/19/2017	0.00
AURORA	HSB	0	00/00/0000	0.00
IL 60504	31140			395.00

GL Number	Description	Invoice Amount	Amount Relieved
94-30-8216.000	Equipment O/M/R Supplies	395.00	0.00

Check No.	0	Total:	395.00
Total for	GOLF INVITE, INC		395.00

GREG NORMAN COLLECTION	Men's Shorts	48098	05/09/2017	
THE CIT GROUP			05/24/2017	
COMMERCIAL SERVICES INC	GRENOR		05/09/2017	0.00
CHARLOTTE	HSB	0	00/00/0000	0.00
NC 28201-1036	0000268078			1,567.62

GL Number	Description	Invoice Amount	Amount Relieved
94-00-1460.000	Pro Shop Inventory	1,567.62	0.00

Check No.	0	Total:	1,567.62
Total for	GREG NORMAN COLLECTION		1,567.62

INVOICE APPROVAL LIST REPORT - DETAIL WITH GL DIST

May 24, 2017

Date: 05/19/2017

Time: 3:06 pm

Page: 7

VILLAGE OF LAKEWOOD

Vendor Name	Invoice Description1	Ref No.	Discount Date	
Vendor Name Line 2	Invoice Description2	PO No.	Pay Date	
Vendor Address	Vendor Number		Due Date	Taxes Withheld
City	Bank	Check No.	Check Date	Discount Amount
State/Province Zip/Postal	Invoice Number			Check Amount

HAWKINS, INC.	Tower 1 Chemicals	48020	05/04/2017	
			05/24/2017	
PO BOX 860263	HAWKINS		05/04/2017	0.00
MINNEAPOLIS	HSB	0	00/00/0000	0.00
MN 55486-0263	4069860			182.00

GL Number	Description	Invoice Amount	Amount Relieved
60-25-8223.000	Chemicals	182.00	0.00

Check No.	0	Total:	182.00
Total for	HAWKINS, INC.		182.00

HD SUPPLY WATERWORKS, LTD	New Phosphate Feed WTP	48022	05/04/2017	
			05/24/2017	
PO BOX 28330	HDSUP		05/04/2017	0.00
ST LOUIS	HSB	0	00/00/0000	0.00
IL 63146	H119591			625.00

GL Number	Description	Invoice Amount	Amount Relieved
60-25-8216.000	Equipment O/M/R Supplies	625.00	0.00

Check No.	0	Total:	625.00
Total for	HD SUPPLY WATERWORKS, LTD		625.00

ILLINOIS EPA	East Sewer IEPA Loan	48082	04/17/2017	
Bureau of Water			05/24/2017	
PO BOX 94438	ILLEPAWAT		04/17/2017	0.00
CHICAGO	HSB	0	00/00/0000	0.00
IL 60690-4438	041717			2,653.28

GL Number	Description	Invoice Amount	Amount Relieved
60-00-8701.000	Principal Payments	2,653.28	0.00

Check No.	0	Total:	2,653.28
Total for	ILLINOIS EPA		2,653.28

INTERNATIONAL CITY COUNTY	Membership- Andrews	48068	05/01/2017	
MANAGEMENT ASSOC.			05/24/2017	
P.O. Box 79403	ICMA		05/01/2017	0.00
Baltimore	HSB	0	00/00/0000	0.00
MD 21279-0403	050117			200.00

GL Number	Description	Invoice Amount	Amount Relieved
10-10-8495.000	Dues & Subscriptions	200.00	0.00

Check No.	0	Total:	200.00
Total for	INTERNATIONAL CITY COUNTY		200.00

INTERNATIONAL INSTITUTE OF	Membership- Hansen	48091	03/31/2017	
MUNICIPAL CLERKS			05/24/2017	
8331 UTICA AVE	INTINS		03/31/2017	0.00
RANCHO CUCAMONGA	HSB	0	00/00/0000	0.00
CA 91730	033117			160.00

GL Number	Description	Invoice Amount	Amount Relieved
10-10-8495.000	Dues & Subscriptions	160.00	0.00

INVOICE APPROVAL LIST REPORT - DETAIL WITH GL DIST

May 24, 2017

Date: 05/19/2017

Time: 3:06 pm

Page: 8

VILLAGE OF LAKEWOOD

Vendor Name	Invoice Description1	Ref No.	Discount Date	
Vendor Name Line 2	Invoice Description2	PO No.	Pay Date	
Vendor Address	Vendor Number	Check No.	Due Date	Taxes Withheld
City	Bank	Check No.	Check Date	Discount Amount
State/Province Zip/Postal	Invoice Number			Check Amount

Check No.	0	Total:	160.00
Total for	INTERNATIONAL INSTITUTE OF		160.00

INTERSTATE BATTERY SYSTEMS	Battery	48059	05/11/2017	
OF FOX RIVER VALLEY			05/24/2017	
333 W. STATE ROAD	INTBAT		05/11/2017	0.00
ISLAND LAKE	HSB	0	00/00/0000	0.00
IL 60042	20114281			80.95

GL Number	Description	Invoice Amount	Amount Relieved
94-40-8416.000	Equipment O/M/R	80.95	0.00

Check No.	0	Total:	80.95
Total for	INTERSTATE BATTERY SYSTEMS		80.95

JCK CONTRACTORS, INC.	22 Yards Topsoil	48106	05/13/2017	
			05/24/2017	
17312 KUNDE ROAD	JCKCON		05/13/2017	0.00
UNION	HSB	0	00/00/0000	0.00
IL 60180	19921			350.00

GL Number	Description	Invoice Amount	Amount Relieved
10-21-8217.000	Grounds M/R Supplies	350.00	0.00

Check No.	0	Total:	350.00
Total for	JCK CONTRACTORS, INC.		350.00

KARLY IRON WORKS, INC	Fabricate 2 Brackets for Sign	48029	05/03/2017	
			05/24/2017	
4014 NW HIGHWAY - 4C	KARIRO		05/03/2017	0.00
CRYSTAL LAKE	HSB	0	00/00/0000	0.00
IL 60014	2068			170.00

GL Number	Description	Invoice Amount	Amount Relieved
10-21-8210.000	Street Signs M/R Supplies	170.00	0.00

Check No.	0	Total:	170.00
Total for	KARLY IRON WORKS, INC		170.00

KERI KOVANIC	Balance Due From Tax Escrow	48083	05/17/2017	
			05/24/2017	
1101 GROVE ST	KOVKER		05/17/2017	0.00
DOWNERS GROVE	HSB	0	00/00/0000	0.00
IL 60515	051717			3,984.94

GL Number	Description	Invoice Amount	Amount Relieved
10-00-1455.000	Prepaid Expenses	3,984.94	0.00

Check No.	0	Total:	3,984.94
Total for	KERI KOVANIC		3,984.94

INVOICE APPROVAL LIST REPORT - DETAIL WITH GL DIST

May 24, 2017

Date: 05/19/2017

Time: 3:06 pm

Page: 9

VILLAGE OF LAKEWOOD

Vendor Name	Invoice Description1	Ref No.	Discount Date	
Vendor Name Line 2	Invoice Description2	PO No.	Pay Date	
Vendor Address	Vendor Number		Due Date	Taxes Withheld
City	Bank	Check No.	Check Date	Discount Amount
State/Province Zip/Postal	Invoice Number			Check Amount

LEADING IT SOLUTIONS	Monthly Service	48034	05/19/2017	
			05/24/2017	
42 EAST STREET	LEASOL		05/19/2017	0.00
CRYSTAL LAKE	HSB	0	00/00/0000	0.00
IL 60014	21303WC			775.00

GL Number	Description	Invoice Amount	Amount Relieved
10-10-8430.000	Computer Services	232.50	0.00
10-15-8430.000	Computer Services	77.50	0.00
10-21-8430.000	Computer Services	77.50	0.00
10-24-8430.000	Computer Services	77.50	0.00
60-00-8430.000	Computer Services	232.50	0.00
94-45-8430.000	Computer Services	77.50	0.00

Check No.	0	Total:	775.00
Total for	LEADING IT SOLUTIONS		775.00

LEE JENSEN SALES CO. INC.	Hoses	48105	05/15/2017	
			05/24/2017	
101 W. TERRA COTTA AVE	LEEJEN		05/15/2017	0.00
CRYSTAL LAKE	HSB	0	00/00/0000	0.00
IL 60014	166849			65.40

GL Number	Description	Invoice Amount	Amount Relieved
10-21-8216.000	Equipment O/M/R Supplies	65.40	0.00

Check No.	0	Total:	65.40
Total for	LEE JENSEN SALES CO. INC.		65.40

MCHENRY COUNTY COLLECTOR	RedTail Dr. Lot 6	48084	05/01/2017	
			05/24/2017	
	MCCOCO		05/01/2017	0.00
	HSB	0	00/00/0000	0.00
	050117A			1,489.16

GL Number	Description	Invoice Amount	Amount Relieved
10-00-1455.000	Prepaid Expenses	1,489.16	0.00

MCHENRY COUNTY COLLECTOR	RedTail Dr. Lot 11	48085	05/01/2017	
			05/24/2017	
	MCCOCO		05/01/2017	0.00
	HSB	0	00/00/0000	0.00
	050117B			1,460.34

GL Number	Description	Invoice Amount	Amount Relieved
10-00-1455.000	Prepaid Expenses	1,460.34	0.00

MCHENRY COUNTY COLLECTOR	RedTail Dr. Lot 17	48086	05/01/2017	
			05/24/2017	
	MCCOCO		05/01/2017	0.00
	HSB	0	00/00/0000	0.00
	050117C			1,347.26

GL Number	Description	Invoice Amount	Amount Relieved
10-00-1455.000	Prepaid Expenses	1,347.26	0.00

MCHENRY COUNTY COLLECTOR	RedTail Dr. Lot 22	48087	05/01/2017	
			05/24/2017	
	MCCOCO		05/01/2017	0.00
	HSB	0	00/00/0000	0.00
	050117D			1,347.26

GL Number	Description	Invoice Amount	Amount Relieved
-----------	-------------	----------------	-----------------

INVOICE APPROVAL LIST REPORT - DETAIL WITH GL DIST

May 24, 2017

Date: 05/19/2017

Time: 3:06 pm

Page: 10

VILLAGE OF LAKEWOOD

Vendor Name	Invoice Description1	Ref No.	Discount Date	
Vendor Name Line 2	Invoice Description2	PO No.	Pay Date	
Vendor Address	Vendor Number	Check No.	Due Date	Taxes Withheld
City	Bank	Check Date	Discount Amount	
State/Province Zip/Postal	Invoice Number		Check Amount	

10-00-1455.000	Prepaid Expenses	1,347.26	0.00	
MCHENRY COUNTY COLLECTOR	RedTail Dr. Lot 24	48088	05/01/2017	
			05/24/2017	
	MCCOCO		05/01/2017	0.00
	HSB	0	00/00/0000	0.00
	050117E			1,347.26

GL Number	Description	Invoice Amount	Amount Relieved
10-00-1455.000	Prepaid Expenses	1,347.26	0.00

Check No.	0	Total:	6,991.28
Total for	MCHENRY COUNTY COLLECTOR		6,991.28

MCMaster-CARR SUPPLY CO.	Fuses	48049	05/03/2017	
			05/24/2017	
P.P. BOX 7690	MCMCAR		05/03/2017	0.00
CHICAGO	HSB	0	00/00/0000	0.00
IL 60680-7690	27543644			31.56

GL Number	Description	Invoice Amount	Amount Relieved
94-40-8416.000	Equipment O/M/R	31.56	0.00

MCMaster-CARR SUPPLY CO.	Nuts	48050	05/03/2017	
			05/24/2017	
P.P. BOX 7690	MCMCAR		05/03/2017	0.00
CHICAGO	HSB	0	00/00/0000	0.00
IL 60680-7690	27542548			11.88

GL Number	Description	Invoice Amount	Amount Relieved
94-40-8305.000	Other, Maintenance Supplies	11.88	0.00

MCMaster-CARR SUPPLY CO.	Hoses	48065	05/09/2017	
			05/24/2017	
P.P. BOX 7690	MCMCAR		05/09/2017	0.00
CHICAGO	HSB	0	00/00/0000	0.00
IL 60680-7690	28812223			58.11

GL Number	Description	Invoice Amount	Amount Relieved
94-40-8288.000	Miscellaneous Supplies	58.11	0.00

Check No.	0	Total:	101.55
Total for	MCMaster-CARR SUPPLY CO.		101.55

MDC ENVIRONMENTAL SERVICES	May Service	48027	05/01/2017	
			05/24/2017	
PO BOX 553915	MDCENV		05/01/2017	0.00
DETROIT	HSB	0	00/00/0000	0.00
MI 48255-3915	17225785			24,361.72

GL Number	Description	Invoice Amount	Amount Relieved
85-00-8491.000	Refuse Service	24,361.72	0.00

Check No.	0	Total:	24,361.72
Total for	MDC ENVIRONMENTAL SERVICES		24,361.72

MENARDS	Wood	48044	05/09/2017	
			05/24/2017	
4850 ROUTE 14	MENARDS		05/09/2017	0.00
CRYSTAL LAKE	HSB	0	00/00/0000	0.00
IL 60014	37370			823.26

INVOICE APPROVAL LIST REPORT - DETAIL WITH GL DIST

May 24, 2017

Date: 05/19/2017

Time: 3:06 pm

Page: 11

VILLAGE OF LAKEWOOD

Vendor Name	Invoice Description1	Ref No.	Discount Date	
Vendor Name Line 2	Invoice Description2	PO No.	Pay Date	
Vendor Address	Vendor Number		Due Date	Taxes Withheld
City	Bank	Check No.	Check Date	Discount Amount
State/Province	Zip/Postal	Invoice Number		Check Amount

GL Number	Description	Invoice Amount	Amount Relieved	
10-21-8210.000	Street Signs M/R Supplies	788.27	0.00	
10-21-8217.000	Grounds M/R Supplies	34.99	0.00	
MENARDS	Gas Can	48057	05/11/2017	
			05/24/2017	
4850 ROUTE 14	MENARDS		05/11/2017	0.00
CRYSTAL LAKE	HSB	0	00/00/0000	0.00
IL 60014	37579			21.76

GL Number	Description	Invoice Amount	Amount Relieved	
94-40-8288.000	Miscellaneous Supplies	21.76	0.00	

Check No.	0	Total:	845.02
Total for	MENARDS		845.02

MINUTEMAN PRESS	5,000 #10 Envelopes	48028	05/04/2017	
			05/24/2017	
835 VIRGINIA ROAD, UNIT G	MINPRE		05/04/2017	0.00
CRYSTAL LAKE	HSB	0	00/00/0000	0.00
IL 60014-8732	82126			331.74

GL Number	Description	Invoice Amount	Amount Relieved	
10-10-8201.000	Printing/Printed Materials	156.90	0.00	
60-00-8201.000	Printing/Printed Materials	174.84	0.00	

Check No.	0	Total:	331.74
Total for	MINUTEMAN PRESS		331.74

MUNICIPAL CLERKS OF LAKE COUNTY	Membership- Hansen	48067	05/01/2017	
			05/24/2017	
C/O DONNA LOBAITO	MUNCLELC		05/01/2017	0.00
HATHORN WOODS	HSB	0	00/00/0000	0.00
IL 60047	050117			20.00

GL Number	Description	Invoice Amount	Amount Relieved	
10-10-8495.000	Dues & Subscriptions	20.00	0.00	

Check No.	0	Total:	20.00
Total for	MUNICIPAL CLERKS OF		20.00

NAPA -AUTO PARTS	Service Truck	48023	05/16/2017	
			05/24/2017	
PO BOX 5066	NAPA		05/16/2017	0.00
ROCKFORD	HSB	0	00/00/0000	0.00
IL 61125	945360			26.90

GL Number	Description	Invoice Amount	Amount Relieved	
60-00-8215.000	Vehicle O/M/R Supplies	26.90	0.00	

NAPA -AUTO PARTS	Shop Towels	48061	05/11/2017	
			05/24/2017	
PO BOX 5066	NAPA		05/11/2017	0.00
ROCKFORD	HSB	0	00/00/0000	0.00
IL 61125	944595			91.80

GL Number	Description	Invoice Amount	Amount Relieved	
94-40-8305.000	Other Maintenance Supplies	91.80	0.00	

INVOICE APPROVAL LIST REPORT - DETAIL WITH GL DIST

May 24, 2017

Date: 05/19/2017

Time: 3:06 pm

Page: 12

VILLAGE OF LAKEWOOD

Vendor Name	Invoice Description1	Ref No.	Discount Date	
Vendor Name Line 2	Invoice Description2	PO No.	Pay Date	
Vendor Address	Vendor Number		Due Date	Taxes Withheld
City	Bank	Check No.	Check Date	Discount Amount
State/Province Zip/Postal	Invoice Number			Check Amount

NAPA -AUTO PARTS	Hazard Light	48104	05/09/2017	
			05/24/2017	
PO BOX 5066	NAPA		05/09/2017	0.00
ROCKFORD	HSB	0	00/00/0000	0.00
IL 61125	944394			16.95

GL Number	Description	Invoice Amount	Amount Relieved
10-21-8215.000	Vehicle O/M/R Supplies	16.95	0.00

Check No.	0	Total:	135.65
Total for	NAPA -AUTO PARTS		135.65

PEPSI COLA GENL BOTTLING	Pop	48058	05/11/2017	
			05/24/2017	
LOCKBOX #75948	PEPSI		05/11/2017	0.00
CHICAGO	HSB	0	00/00/0000	0.00
IL 60675-5948	97965956			183.54

GL Number	Description	Invoice Amount	Amount Relieved
94-00-1470.000	Food & Beverage Inventory	183.54	0.00

Check No.	0	Total:	183.54
Total for	PEPSI COLA GENL BOTTLING		183.54

CURT A PETERSON	Lessons	48056	05/16/2017	
			05/24/2017	
2811 BRAEBURN WAY	PETCUR		05/16/2017	0.00
WOODSTOCK	HSB	0	00/00/0000	0.00
IL 60098	7003			2,416.00

GL Number	Description	Invoice Amount	Amount Relieved
94-30-3657.001	Instruction/Lesson Costs	2,416.00	0.00

Check No.	0	Total:	2,416.00
Total for	CURT A PETERSON		2,416.00

PGA OF AMERICA-IL SECTION	Membership Dues- Neuhart	48048	05/01/2017	
ATTN: Acouunts Receivable			05/24/2017	
PO BOX 31089	PGA		05/01/2017	0.00
PALM BEACH GARDENS	HSB	0	00/00/0000	0.00
FL 33420-1089	050117			734.00

GL Number	Description	Invoice Amount	Amount Relieved
94-30-8495.000	Dues & Subscriptions	734.00	0.00

Check No.	0	Total:	734.00
Total for	PGA OF AMERICA-IL SECTION		734.00

PING, INC.	Ping Hat	48069	05/03/2017	
			05/24/2017	
P.O. BOX 52450	PING		05/03/2017	0.00
PHOENIX	HSB	0	00/00/0000	0.00
AZ 85072-2450	13726666			96.84

GL Number	Description	Invoice Amount	Amount Relieved
94-00-1460.000	Pro Shop Inventory	101.34	0.00
94-00-1461.000	Pro Shop Inventory Discounts	-4.50	0.00

INVOICE APPROVAL LIST REPORT - DETAIL WITH GL DIST

May 24, 2017

Date: 05/19/2017

Time: 3:06 pm

Page: 13

VILLAGE OF LAKEWOOD

Vendor Name	Invoice Description1	Ref No.	Discount Date	
Vendor Name Line 2	Invoice Description2	PO No.	Pay Date	
Vendor Address	Vendor Number		Due Date	Taxes Withheld
City	Bank	Check No.	Check Date	Discount Amount
State/Province Zip/Postal	Invoice Number			Check Amount

Check No.	0	Total:	96.84
Total for	PING, INC.		96.84

PITEL SEPTIC, INC.	Porta Potty	48075	05/01/2017	
			05/24/2017	
PO BOX 193	PITSEP		05/01/2017	0.00
RINGWOOD	HSB	0	00/00/0000	0.00
IL 60072	13924			400.00

GL Number	Description	Invoice Amount	Amount Relieved
94-40-8490.000	Contractual Services - NEC	400.00	0.00

Check No.	0	Total:	400.00
Total for	PITEL SEPTIC, INC.		400.00

R&R PRODUCTS, INC.	Cup Puller	48047	05/02/2017	
			05/24/2017	
3334 EAST MILBER ST	R&RPRO		05/02/2017	0.00
TUCSON	HSB	0	00/00/0000	0.00
AZ 85714	CD2118119			24.48

GL Number	Description	Invoice Amount	Amount Relieved
94-40-8305.000	Other, Maintenance Supplies	24.48	0.00

R&R PRODUCTS, INC.	Long Sleeve Shirts	48062	05/05/2017	
			05/24/2017	
3334 EAST MILBER ST	R&RPRO		05/05/2017	0.00
TUCSON	HSB	0	00/00/0000	0.00
AZ 85714	CD2119636			54.46

GL Number	Description	Invoice Amount	Amount Relieved
94-40-8251.000	Wearing Apparel	54.46	0.00

R&R PRODUCTS, INC.	Piston	48063	05/05/2017	
			05/24/2017	
3334 EAST MILBER ST	R&RPRO		05/05/2017	0.00
TUCSON	HSB	0	00/00/0000	0.00
AZ 85714	CD2119767			40.98

GL Number	Description	Invoice Amount	Amount Relieved
94-40-8416.000	Equipment O/M/R	40.98	0.00

Check No.	0	Total:	119.92
Total for	R&R PRODUCTS, INC.		119.92

RALPH HELM, INC.	Water Pump	48070	05/08/2017	
			05/24/2017	
36W710 Foothill Road	RALHEL		05/08/2017	0.00
Elgin	HSB	0	00/00/0000	0.00
IL 60123	84512			548.77

GL Number	Description	Invoice Amount	Amount Relieved
94-40-8305.000	Other, Maintenance Supplies	548.77	0.00

Check No.	0	Total:	548.77
Total for	RALPH HELM, INC.		548.77

INVOICE APPROVAL LIST REPORT - DETAIL WITH GL DIST

May 24, 2017

Date: 05/19/2017

Time: 3:06 pm

Page: 14

VILLAGE OF LAKEWOOD

Vendor Name	Invoice Description1	Ref No.	Discount Date	
Vendor Name Line 2	Invoice Description2	PO No.	Pay Date	
Vendor Address	Vendor Number	Check No.	Due Date	Taxes Withheld
City	Bank	Check Date	Check Date	Discount Amount
State/Province Zip/Postal	Invoice Number			Check Amount

REINDERS	Belts	48045	05/03/2017	
			05/24/2017	
PO BOX 78955	REINDERS		05/03/2017	0.00
MILWAUKEE	HSB	0	00/00/0000	0.00
WI 53278-0955	1683161			146.92

GL Number	Description	Invoice Amount	Amount Relieved
94-40-8416.000	Equipment O/M/R	146.92	0.00

REINDERS	Fertilizers	48046	05/02/2017	
			05/24/2017	
PO BOX 78955	REINDERS		05/02/2017	0.00
MILWAUKEE	HSB	0	00/00/0000	0.00
WI 53278-0955	4246181			2,874.78

GL Number	Description	Invoice Amount	Amount Relieved
94-40-8311.000	Fertilizer	2,874.78	0.00

REINDERS	Wheel, Rim, Blade	48064	05/08/2017	
			05/24/2017	
PO BOX 78955	REINDERS		05/08/2017	0.00
MILWAUKEE	HSB	0	00/00/0000	0.00
WI 53278-0955	1683398			239.11

GL Number	Description	Invoice Amount	Amount Relieved
94-40-8416.000	Equipment O/M/R	239.11	0.00

REINDERS	Rim	48066	05/09/2017	
			05/24/2017	
PO BOX 78955	REINDERS		05/09/2017	0.00
MILWAUKEE	HSB	0	00/00/0000	0.00
WI 53278-0955	1683398-01			55.40

GL Number	Description	Invoice Amount	Amount Relieved
94-40-8416.000	Equipment O/M/R	55.40	0.00

Check No.	0	Total:	3,316.21
Total for	REINDERS		3,316.21

REV TECH PLUS LLC	Advertisement May	48037	05/01/2017	
			05/24/2017	
8401 CLAUDE THOMAS ROAD	REVTEC		05/01/2017	0.00
FRANKLIN	HSB	0	00/00/0000	0.00
OH 45005	1419			1,500.00

GL Number	Description	Invoice Amount	Amount Relieved
94-45-8456.000	Advertising	1,500.00	0.00

Check No.	0	Total:	1,500.00
Total for	REV TECH PLUS LLC		1,500.00

SAM'S CLUB CREDIT	Supplies	48108	05/02/2017	
			05/24/2017	
PO BOX 530981	SAMCLUR		05/02/2017	0.00
ATLANTA	HSB	0	00/00/0000	0.00
GA 30353-0981	050217			1,104.10

GL Number	Description	Invoice Amount	Amount Relieved
94-00-1470.000	Food & Beverage Inventory	390.53	0.00
94-30-8202.000	Office Supplies	57.89	0.00
94-30-8350.000	Cleaning Supplies	134.70	0.00
94-35-8207.000	Cleaning Supplies	67.12	0.00
94-35-8222.000	Paper Products	78.15	0.00

INVOICE APPROVAL LIST REPORT - DETAIL WITH GL DIST

May 24, 2017

Date: 05/19/2017

Time: 3:06 pm

Page: 15

VILLAGE OF LAKEWOOD

Vendor Name	Invoice Description1	Ref No.	Discount Date	
Vendor Name Line 2	Invoice Description2	PO No.	Pay Date	
Vendor Address	Vendor Number		Due Date	Taxes Withheld
City	Bank	Check No.	Check Date	Discount Amount
State/Province Zip/Postal	Invoice Number			Check Amount

94-45-8414.000	Building Maintenance & Repairs	285.71	0.00	
94-45-8495.000	Dues & Subscriptions	90.00	0.00	

Check No.	0	Total:	1,104.10
Total for	SAM'S CLUB CREDIT		1,104.10

SEECOM	Dispatch Services	48054	05/01/2017	
			05/24/2017	
100 WEST WOODSTOCK STREET	SEECOM		05/01/2017	0.00
CRYSTAL LAKE	HSB	0	00/00/0000	0.00
IL 60014	989			15,220.76

GL Number	Description	Invoice Amount	Amount Relieved
10-15-8441.000	Dispatch Services	15,220.76	0.00

Check No.	0	Total:	15,220.76
Total for	SEECOM		15,220.76

SOCIETY FOR HUMAN RESOURCE MANAGEMENT	Membership- Villie	48093	05/19/2017	
			05/24/2017	
P.O BOX 79482	SHRM		05/19/2017	0.00
BALTIMORE	HSB	0	00/00/0000	0.00
MD 21279-0482	051917			199.00

GL Number	Description	Invoice Amount	Amount Relieved
10-10-8495.000	Dues & Subscriptions	199.00	0.00

Check No.	0	Total:	199.00
Total for	SOCIETY FOR HUMAN RESOURCE		199.00

SOIL TECHNOLOGIES CORP.	TurfTech	48101	01/09/2017	
			05/24/2017	
2103 185TH STREET	SOITEC		01/09/2017	0.00
FAIRFIELD	HSB	0	00/00/0000	0.00
IA 52556-9232	61686			3,173.00

GL Number	Description	Invoice Amount	Amount Relieved
94-40-8311.000	Fertilizer	3,173.00	0.00

Check No.	0	Total:	3,173.00
Total for	SOIL TECHNOLOGIES CORP.		3,173.00

SYSCO FOOD SVCS	F&B Supplies	48103	05/10/2017	
			05/24/2017	
PO BOX 5037	SYSFOO		05/10/2017	0.00
DES PLAINES	HSB	0	00/00/0000	0.00
IL 60017-5037	124423783			607.50

GL Number	Description	Invoice Amount	Amount Relieved
94-00-1470.000	Food & Beverage Inventory	394.19	0.00
94-35-8222.000	Paper Products	213.31	0.00

Check No.	0	Total:	607.50
Total for	SYSCO FOOD SVCS		607.50

INVOICE APPROVAL LIST REPORT - DETAIL WITH GL DIST

May 24, 2017

Date: 05/19/2017

Time: 3:08 pm

Page: 16

VILLAGE OF LAKEWOOD

Vendor Name	Invoice Description 1	Ref No.	Discount Date	
Vendor Name Line 2	Invoice Description 2	PO No.	Pay Date	
Vendor Address	Vendor Number		Due Date	Taxes Withheld
City	Bank	Check No.	Check Date	Discount Amount
State/Province Zip/Postal	Invoice Number			Check Amount
TITLEIST DRAWER CS	Golf Balls	48097	09/22/2016	
Acushnet Company			05/24/2017	
P.O. BOX 88112	TITLEIST		09/22/2016	0.00
CHICAGO	HSB	0	00/00/0000	0.00
IL 60695-1112	904149427			3,481.22

GL Number	Description	Invoice Amount	Amount Relieved
94-00-1460.000	Pro Shop Inventory	3,550.10	0.00
94-00-1461.000	Pro Shop Inventory, Discounts	-68.88	0.00

Check No.	0	Total:	3,481.22
Total for	TITLEIST DRAWER CS		3,481.22

Vendor Name	Invoice Description 1	Ref No.	Discount Date	
Vendor Name Line 2	Invoice Description 2	PO No.	Pay Date	
Vendor Address	Vendor Number		Due Date	Taxes Withheld
City	Bank	Check No.	Check Date	Discount Amount
State/Province Zip/Postal	Invoice Number			Check Amount
TOUR EDGE GOLF MFG. INC.	Special Order Bag	48074	05/03/2017	
			05/24/2017	
1301 PIERSON DRIVE	TOUEDG		05/03/2017	0.00
BATAVIA	HSB	0	00/00/0000	0.00
IL 60510	IN-01145324			208.96

GL Number	Description	Invoice Amount	Amount Relieved
94-00-1460.000	Pro Shop Inventory	213.00	0.00
94-00-1461.000	Pro Shop Inventory, Discounts	-4.04	0.00

Check No.	0	Total:	208.96
Total for	TOUR EDGE GOLF MFG. INC.		208.96

Vendor Name	Invoice Description 1	Ref No.	Discount Date	
Vendor Name Line 2	Invoice Description 2	PO No.	Pay Date	
Vendor Address	Vendor Number		Due Date	Taxes Withheld
City	Bank	Check No.	Check Date	Discount Amount
State/Province Zip/Postal	Invoice Number			Check Amount
VILLAGE OF LAKEWOOD	RedTail Water/Sewer	48032	05/08/2017	
			05/24/2017	
2500 Lake Avenue	VILLAK		05/08/2017	0.00
Village of Lakewood	HSB	0	00/00/0000	0.00
IL 60014	050817A			174.40

GL Number	Description	Invoice Amount	Amount Relieved
94-45-8446.000	Water & Sewer	174.40	0.00

Vendor Name	Invoice Description 1	Ref No.	Discount Date	
Vendor Name Line 2	Invoice Description 2	PO No.	Pay Date	
Vendor Address	Vendor Number		Due Date	Taxes Withheld
City	Bank	Check No.	Check Date	Discount Amount
State/Province Zip/Postal	Invoice Number			Check Amount
VILLAGE OF LAKEWOOD	RedTail Water & Sewer	48033	05/08/2017	
			05/24/2017	
2500 Lake Avenue	VILLAK		05/08/2017	0.00
Village of Lakewood	HSB	0	00/00/0000	0.00
IL 60014	050817B			156.70

GL Number	Description	Invoice Amount	Amount Relieved
94-40-8446.000	Water & Sewer	156.70	0.00

Check No.	0	Total:	331.10
Total for	VILLAGE OF LAKEWOOD		331.10

Vendor Name	Invoice Description 1	Ref No.	Discount Date	
Vendor Name Line 2	Invoice Description 2	PO No.	Pay Date	
Vendor Address	Vendor Number		Due Date	Taxes Withheld
City	Bank	Check No.	Check Date	Discount Amount
State/Province Zip/Postal	Invoice Number			Check Amount
WATER ONE	Water- RedTail Barn	48040	05/04/2017	
			05/24/2017	
960 MUIRFIELD DRIVE	WATONE		05/04/2017	0.00
HANOVER PARK	HSB	0	00/00/0000	0.00
IL 60133	42644TG			18.75

GL Number	Description	Invoice Amount	Amount Relieved
94-40-8490.000	Contractual Services - NEC	18.75	0.00

INVOICE APPROVAL LIST REPORT - DETAIL WITH GL DIST

May 24, 2017

Date: 05/19/2017

Time: 3:06 pm

Page: 17

VILLAGE OF LAKEWOOD

Vendor Name	Invoice Description1	Ref No.	Discount Date	
Vendor Name Line 2	Invoice Description2	PO No.	Pay Date	
Vendor Address	Vendor Number	Bank	Due Date	Taxes Withheld
City	Bank	Check No.	Check Date	Discount Amount
State/Province Zip/Postal	Invoice Number			Check Amount

WATER ONE	Water- VH	48041	05/04/2017	
			05/24/2017	
960 MUIRFIELD DRIVE	WATONE		05/04/2017	0.00
HANOVER PARK	HSB	0	00/00/0000	0.00
IL 60133	42642TG			25.00

GL Number	Description	Invoice Amount	Amount Relieved
10-10-8490.000	Contractual Services - NEC	25.00	0.00

WATER ONE	Water- PW	48042	05/04/2017	
			05/24/2017	
960 MUIRFIELD DRIVE	WATONE		05/04/2017	0.00
HANOVER PARK	HSB	0	00/00/0000	0.00
IL 60133	42643TG			18.75

GL Number	Description	Invoice Amount	Amount Relieved
10-21-8490.000	Contractual Services - NEC	9.37	0.00
60-00-8490.000	Contractual Services - NEC	9.38	0.00

Check No.	0	Total:	62.50
Total for	WATER ONE		62.50

WATER RESOURCES, INC.	Meter Reading Support	48021	05/11/2017	
			05/24/2017	
390 Sadler Avenue	WATRES		05/11/2017	0.00
Elgin	HSB	0	00/00/0000	0.00
IL 60120-8038	31412			2,250.00

GL Number	Description	Invoice Amount	Amount Relieved
60-00-8430.000	Computer Services	2,250.00	0.00

Check No.	0	Total:	2,250.00
Total for	WATER RESOURCES, INC.		2,250.00

WILLIAMS-MANNY, INC.	May Fee	48089	05/01/2017	
		n	05/24/2017	
555 S. PERRYVILLE ROAD	WILMAN		05/01/2017	0.00
ROCKFORD	HSB	0	00/00/0000	0.00
IL 61125-0466	18187			96.00

GL Number	Description	Invoice Amount	Amount Relieved
10-10-8163.000	Health Insurance	4.50	0.00
10-15-8163.000	Health Insurance	42.00	0.00
10-21-8163.000	Health Insurance	14.40	0.00
60-00-8163.000	Health Insurance	19.20	0.00
85-00-8163.000	Health Insurance	0.60	0.00
94-30-8163.000	Health Insurance	6.00	0.00
94-40-8163.000	Health Insurance	6.00	0.00
94-45-8163.000	Health Insurance	3.30	0.00

Check No.	0	Total:	96.00
Total for	WILLIAMS-MANNY, INC.		96.00

WRONA BROS. INC.	Labels	48038	05/02/2017	
			05/24/2017	
205 EAST CHICAGO STREET	WROBRO		05/02/2017	0.00
ELGIN	HSB	0	00/00/0000	0.00
IL 60120	0126658-001			19.98

INVOICE APPROVAL LIST REPORT - DETAIL WITH GL DIST

May 24, 2017

Date: 05/19/2017

Time: 3:06 pm

Page: 18

VILLAGE OF LAKEWOOD

Vendor Name	Invoice Description1	Ref No.	Discount Date	
Vendor Name Line 2	Invoice Description2	PO No.	Pay Date	
Vendor Address	Vendor Number		Due Date	Taxes Withheld
City	Bank	Check No.	Check Date	Discount Amount
State/Province Zip/Postal	Invoice Number			Check Amount

GL Number	Description	Invoice Amount	Amount Relieved
10-10-8202.000	Office Supplies	19.98	0.00

Check No.	0	Total:	19.98
Total for	WRONA BROS. INC.		19.98

Total Invoices: 86

Grand Total:	345,061.05
Less Credit Memos:	0.00
Net Total:	345,061.05
Less Hand Check Total:	0.00
Outstanding Invoice Total:	345,061.05

INVOICE APPROVAL LIST BY FUND
 May 24, 2017

Date: 05/19/2017
 Time: 3:07pm
 Page: 1

VILLAGE OF LAKEWOOD

Fund Department Account	GL Number Abbrev	Vendor Name Invoice Description	Check Number	Invoice Number	Due Date	Amount
Fund: General Fund						
Dept: Non-Department						
10-00-1455.000	Prepaid Ex	KERI KOVANIC	0		05/17/2017	3,984.94
		Balance Due From Tax Escrow		051717		
10-00-1455.000	Prepaid Ex	MCHENRY COUNTY COLLECTOR	0		05/01/2017	1,489.16
		RedTail Dr. Lot 6		050117A		
10-00-1455.000	Prepaid Ex	MCHENRY COUNTY COLLECTOR	0		05/01/2017	1,460.34
		RedTail Dr. Lot 11		050117B		
10-00-1455.000	Prepaid Ex	MCHENRY COUNTY COLLECTOR	0		05/01/2017	1,347.26
		RedTail Dr. Lot 17		050117C		
10-00-1455.000	Prepaid Ex	MCHENRY COUNTY COLLECTOR	0		05/01/2017	1,347.26
		RedTail Dr. Lot 22		050117D		
10-00-1455.000	Prepaid Ex	MCHENRY COUNTY COLLECTOR	0		05/01/2017	1,347.26
		RedTail Dr. Lot 24		050117E		
		Total Non-Department				10,976.22
Dept: Administration						
10-10-8163.000	Health Ins	WILLIAMS-MANNY, INC.	0		05/01/2017	4.50
		May Fee		18187		
10-10-8201.000	Printing/P	MINUTEMAN PRESS	0		05/04/2017	156.90
		5,000 #10 Envelopes		82126		
10-10-8202.000	Office Sup	WRONA BROS. INC.	0		05/02/2017	19.98
		Labels		0126658-001		
10-10-8430.000	Computer S	LEADING IT SOLUTIONS	0		05/19/2017	232.50
		Monthly Service		21303WC		
10-10-8440.000	Telephone	CALL ONE	0		05/15/2017	218.23
		Monthly Service		051517		
10-10-8490.000	Contractua	WATER ONE	0		05/04/2017	25.00
		Water- VH		42642TG		
10-10-8495.000	Dues & Sub	CRYSTAL LAKE CHAMBER	0		05/19/2017	499.00
		Membership 6/1/17-5/31/18		95011		
10-10-8495.000	Dues & Sub	MUNICIPAL CLERKS OF	0		05/01/2017	20.00
		Membership- Hansen		050117		
10-10-8495.000	Dues & Sub	INTERNATIONAL CITY COUNTY	0		05/01/2017	200.00
		Membership- Andrews		050117		
10-10-8495.000	Dues & Sub	INTERNATIONAL INSTITUTE OF	0		03/31/2017	160.00
		Membership- Hansen		033117		
10-10-8495.000	Dues & Sub	SOCIETY FOR HUMAN RESOURCE	0		05/19/2017	199.00
		Membership- Villie		051917		
		Total Administration				1,735.11
Dept: Police Department						
10-15-8163.000	Health Ins	WILLIAMS-MANNY, INC.	0		05/01/2017	42.00
		May Fee		18187		
10-15-8260.000	Mileage Re	ALLY	0		05/11/2017	242.96
		Chief's Car Lease		051117		
10-15-8430.000	Computer S	LEADING IT SOLUTIONS	0		05/19/2017	77.50
		Monthly Service		21303RC		
10-15-8440.000	Telephone	CALL ONE	0		05/15/2017	257.94
		Monthly Service		051517		
10-15-8441.000	Dispatch S	SEECOM	0		05/01/2017	15,220.76
		Dispatch Services		989		
10-15-8443.000	Fire Prot	CITY OF CRYSTAL LAKE	0		05/01/2017	63,924.14
		June Fire Services		0016576		
		Total Police Department				79,765.30
Dept: Public Works Department						
10-21-8163.000	Health Ins	WILLIAMS-MANNY, INC.	0		05/01/2017	14.40
		May Fee		18187		
10-21-8170.000	Physicals/	CENTEGRA OCCUPATIONAL HEALTH	0		05/15/2017	30.00
		Pre Employ (2 EE)		190503		
10-21-8210.000	Street Sig	KARLY IRON WORKS, INC	0		05/03/2017	170.00
		Fabricate 2 Brackets for Sign		2068		
10-21-8210.000	Street Sig	MENARDS	0		05/09/2017	788.27
		Wood		37370		
10-21-8212.000	Street Lig	ACE HARDWARE	0		05/03/2017	27.04
		Fasteners		103309		
10-21-8215.000	Vehicle O/	NAPA -AUTO PARTS	0		05/09/2017	16.95
		Hazard Light		944394		
10-21-8216.000	Equip OMR	LEE JENSEN SALES CO. INC.	0		05/15/2017	65.40
		Hoses		166849		
10-21-8217.000	Grounds M/	MENARDS	0		05/09/2017	34.99
		Wood		37370		

INVOICE APPROVAL LIST BY FUND
May 24, 2017

Date: 05/19/2017
Time: 3:07pm
Page: 2

VILLAGE OF LAKEWOOD

Fund	Department	Account	GL Number Abbrev	Vendor Name Invoice Description	Check Number	Invoice Number	Due Date	Amount
Fund: General Fund								
Dept: Public Works Department								
		10-21-8217.000	Grounds M/	JCK CONTRACTORS, INC. 22 Yards Topsoil	0	19921	05/13/2017	350.00
		10-21-8250.000	Bituminous	GESKE & SONS, INC. 1 Ton Asphalt Cold Patch	0	37924	05/08/2017	145.00
		10-21-8401.000	Rental Equ	ED'S RENTAL Dolly Rental	0	197536-2	05/17/2017	20.00
		10-21-8417.000	Grounds Ma	ANDERSON PEST CONTROL Pest Control- VH	0	4259214	05/01/2017	51.36
		10-21-8418.000	Tree Maint	FJR TREE SERVICE, INC. Remove 6 Trees	0	4674	05/03/2017	1,750.00
		10-21-8430.000	Computer S	LEADING IT SOLUTIONS Monthly Service	0	21303KC	05/19/2017	77.50
		10-21-8490.000	Contractua	WATER ONE Water- PW	0	42643TG	05/04/2017	9.37
		10-21-8495.000	Dues & Sub	AMERICAN PUBLIC WORKS ASSOC. Membership Renewal	0	050517	05/05/2017	320.00
								3,870.28
Total Public Works Department								
Dept: Building Department								
		10-24-8430.000	Computer S	LEADING IT SOLUTIONS Monthly Service	0	21303KC	05/19/2017	77.50
		10-24-8440.000	Telephone	CALL ONE Monthly Service	0	051517	05/15/2017	43.93
								121.43
Total Building Department								
								96,468.34
Fund Total								
Fund: Lakewood Utilities								
Dept: Non-Department								
		60-00-8163.000	Health Ins	WILLIAMS-MANNY, INC. May Fee	0	18187	05/01/2017	19.20
		60-00-8201.000	Printing/P	MINUTEMAN PRESS 5,000 #10 Envelopes	0	82126	05/04/2017	174.84
		60-00-8215.000	Vehicle O/	NAPA -AUTO PARTS Service Truck	0	945360	05/16/2017	26.90
		60-00-8430.000	Computer S	WATER RESOURCES, INC. Meter Reading Support	0	31412	05/11/2017	2,250.00
		60-00-8430.000	Computer S	LEADING IT SOLUTIONS Monthly Service	0	21303KC	05/19/2017	232.50
		60-00-8440.000	Telephone	CALL ONE Monthly Service	0	051517	05/15/2017	489.21
		60-00-8440.000	Telephone	CALL ONE Monthly Service	0	051517B	05/15/2017	47.92
		60-00-8490.000	Contractua	WATER ONE Water- PW	0	42643TG	05/04/2017	9.38
		60-00-8700.000	Paying Age	AMALGAMATED BANK OF CHICAGO Paying Agent Fee 2010B	0	050117A	05/01/2017	475.00
		60-00-8700.000	Paying Age	AMALGAMATED BANK OF CHICAGO Paying Agent Fee 2010A	0	050117B	05/01/2017	475.00
		60-00-8701.000	Principal	ILLINOIS EPA East Sewer IEPA Loan	0	041717	04/17/2017	2,653.28
		60-00-8702.080	Int-2010A	AMALGAMATED BANK OF CHICAGO Tower 1 Series 2010A	0	050117D	05/01/2017	50,846.75
		60-00-8702.085	Int-2010B	AMALGAMATED BANK OF CHICAGO WWTP Bond Series 2010B	0	050117C	05/01/2017	131,284.38
								188,984.36
Total Non-Department								
Dept: Water Department								
		60-25-8216.000	Equip OMR	HD SUPPLY WATERWORKS, LTD New Phosphate Feed WTP	0	H119591	05/04/2017	625.00
		60-25-8223.000	Chemicals	HAWKINS, INC. Tower 1 Chemicals	0	4069860	05/04/2017	182.00
								807.00
Total Water Department								
								189,791.36
Fund Total								

Fund: Special Service Area #8
Dept: Non-Department

INVOICE APPROVAL LIST BY FUND
May 24, 2017

Date: 05/19/2017
Time: 3:07pm
Page: 3

VILLAGE OF LAKEWOOD

Fund	Department	GL Number	Vendor Name	Check	Invoice	Due	Amount
Account	Account	Abbrev	Invoice Description	Number	Number	Date	
Fund: Special Service Area #8							
Dept: Non-Department							
72-00-8408.000	Lake Treat		ENVIRONMENTAL AQUATIC MGMT LLC Weekly Pond Management 2017	0	10144	05/01/2017	10,000.00

Total Non-Department							10,000.00

Fund Total							10,000.00
Fund: Refuse Fund							
Dept: Non-Department							
85-00-8163.000	Health Ins		WILLIAMS-MANNY, INC. May Fee	0	18187	05/01/2017	0.60
85-00-8491.000	Refuse Ser		MDC ENVIRONMENTAL SERVICES May Service	0	17225785	05/01/2017	24,361.72

Total Non-Department							24,362.32

Fund Total							24,362.32
Fund: Lake Patrol Fund							
Dept: Non-Department							
92-00-8170.000	Physicals/		CENTEGRA OCCUPATIONAL HEALTH Pre Employ (1 EE)	0	190238	05/09/2017	30.00
92-00-8416.000	Equipment		CAPTAIN ROD'S - BRR INC. Install Bouys	0	32017B	05/19/2017	240.00

Total Non-Department							270.00

Fund Total							270.00
Fund: Golf Course Fund							
Dept: Non-Department							
94-00-1460.000	Pro Shop I		PING, INC. Ping Hat	0	13726666	05/03/2017	101.34
94-00-1460.000	Pro Shop I		TOUR EDGE GOLF MFG. INC. Special Order Bag	0	IN-01145324	05/03/2017	213.00
94-00-1460.000	Pro Shop I		CERTI FRESH CIGARS Cigars	0	28324	05/08/2017	1,357.48
94-00-1460.000	Pro Shop I		TITLEIST DRAWER CS Golf Balls	0	904149427	09/22/2016	3,550.10
94-00-1460.000	Pro Shop I		GREG NORMAN COLLECTION Men's Shorts	0	0000268078	05/09/2017	1,567.62
94-00-1461.000	Pro Shop I		PING, INC. Ping Hat	0	13726666	05/03/2017	-4.50
94-00-1461.000	Pro Shop I		TOUR EDGE GOLF MFG. INC. Special Order Bag	0	IN-01145324	05/03/2017	-4.04
94-00-1461.000	Pro Shop I		TITLEIST DRAWER CS Golf Balls	0	904149427	09/22/2016	-68.88
94-00-1470.000	Food & Bev		PEPSI COLA GENL BOTTLING Pop	0	97965956	05/11/2017	183.54
94-00-1470.000	Food & Bev		SYSCO FOOD SVCS F&B Supplies	0	124423783	05/10/2017	394.19
94-00-1470.000	Food & Bev		SAM'S CLUB CREDIT Supplies	0	050217	05/02/2017	390.53

Total Non-Department							7,680.38
Dept: Golf Course/Pro Shop							
94-30-3657.001	Instructio		CURT A PETERSON Lessons	0	7003	05/16/2017	2,416.00
94-30-8163.000	Health Ins		WILLIAMS-MANNY, INC. May Fee	0	18187	05/01/2017	6.00
94-30-8170.000	Physicals/		CENTEGRA OCCUPATIONAL HEALTH Pre Employ (1 EE)	0	190580	05/16/2017	30.00
94-30-8202.000	Office Sup		SAM'S CLUB CREDIT Supplies	0	050217	05/02/2017	57.89
94-30-8206.000	Range Supp		CRYSTAL LAKE COUNTRY CLUB Golf Balls	0	11	05/01/2017	800.00
94-30-8216.000	Equip CMR		GOLF INVITE, INC Golf Ball Launcher Rental	0	31140	05/19/2017	395.00
94-30-8350.000	Cleaning S		SAM'S CLUB CREDIT Supplies	0	050217	05/02/2017	134.70

INVOICE APPROVAL LIST BY FUND
May 24, 2017

Date: 05/19/2017
Time: 3:07pm
Page: 4

VILLAGE OF LAKEWOOD

Fund	Department	GL Number	Vendor Name	Check	Invoice	Due	Amount
Account	Account	Abbrev	Invoice Description	Number	Number	Date	
Fund: Golf Course Fund							
Dept: Golf Course/Pro Shop							
94-30-8495.000	Dues & Sub		PGA OF AMERICA-IL SECTION Membership Dues- Neuhart	0	050117	05/01/2017	734.00

Total Golf Course/Pro Shop							4,573.59
Dept: Food & Beverage Department							
94-35-8170.000	Physicals/		CENTEGRA OCCUPATIONAL HEALTH Pre Employ (2 EE)	0	190503	05/15/2017	30.00
94-35-8207.000	Cleaning S		SAM'S CLUB CREDIT Supplies	0	050217	05/02/2017	67.12
94-35-8222.000	Paper Prod		SYSCO FOOD SVCS F&B Supplies	0	124423783	05/10/2017	213.31
94-35-8222.000	Paper Prod		SAM'S CLUB CREDIT Supplies	0	050217	05/02/2017	78.15

Total Food & Beverage Department							388.58
Dept: Course Maintenance Department							
94-40-8163.000	Health Ins		WILLIAMS-MANNY, INC. May Fee	0	18187	05/01/2017	6.00
94-40-8170.000	Physicals/		CENTEGRA OCCUPATIONAL HEALTH Pre Employ (1EE)	0	190169	05/08/2017	30.00
94-40-8251.000	Wearing Ap		R&R PRODUCTS, INC. Long Sleeve Shirts	0	CD2119636	05/05/2017	54.46
94-40-8288.000	Miscellaneous		MENARDS Gas Can	0	37579	05/11/2017	21.76
94-40-8288.000	Miscellaneous		MCMASTER-CARR SUPPLY CO. Hoses	0	28812223	05/09/2017	58.11
94-40-8305.000	Other, Mai		NAPA -AUTO PARTS Shop Towels	0	944595	05/11/2017	91.80
94-40-8305.000	Other, Mai		R&R PRODUCTS, INC. Cup Puller	0	CD2118119	05/02/2017	24.48
94-40-8305.000	Other, Mai		MCMASTER-CARR SUPPLY CO. Nuts	0	27542548	05/03/2017	11.88
94-40-8305.000	Other, Mai		RALPH HELM, INC. Water Pump	0	84512	05/08/2017	548.77
94-40-8311.000	Fertilizer		REINDERS Fertilizers	0	4246181	05/02/2017	2,874.78
94-40-8311.000	Fertilizer		SOIL TECHNOLOGIES CORP. TurfTech	0	61686	01/09/2017	3,173.00
94-40-8416.000	Equipment		R&R PRODUCTS, INC. Piston	0	CD2119767	05/05/2017	40.98
94-40-8416.000	Equipment		REINDERS Belts	0	1683161	05/03/2017	146.92
94-40-8416.000	Equipment		MCMASTER-CARR SUPPLY CO. Fuses	0	27543644	05/03/2017	31.56
94-40-8416.000	Equipment		INTERSTATE BATTERY SYSTEMS Battery	0	20114281	05/11/2017	80.95
94-40-8416.000	Equipment		CASSIDY TIRES & SERVICE Tires	0	6053941	04/17/2017	126.92
94-40-8416.000	Equipment		REINDERS Wheel, Rim, Blade	0	1683398	05/08/2017	239.11
94-40-8416.000	Equipment		REINDERS Rim	0	1683398-01	05/09/2017	55.40
94-40-8440.000	Telephone		CALL ONE Monthly Service	0	051517	05/15/2017	43.98
94-40-8446.000	Water & Se		VILLAGE OF LAKEWOOD RedTail Water & Sewer	0	050817B	05/08/2017	156.70
94-40-8490.000	Contractua		WATER ONE Water- RedTail Barn	0	42644TG	05/04/2017	18.75
94-40-8490.000	Contractua		PITEL SEPTIC, INC. Porta Potty	0	13924	05/01/2017	400.00

Total Course Maintenance Department							8,236.31
Dept: General & Administrative Dept							
94-45-8163.000	Health Ins		WILLIAMS-MANNY, INC. May Fee	0	18187	05/01/2017	3.30
94-45-8414.000	Building M		FOX VALLEY FIRE & SAFETY Service Extinguisher	0	IN00084764	05/04/2017	291.05
94-45-8414.000	Building M		ANDERSON PEST CONTROL Pest Management- RedTail	0	4257825	05/01/2017	46.84
94-45-8414.000	Building M		SAM'S CLUB CREDIT Supplies	0	050217	05/02/2017	285.71

INVOICE APPROVAL LIST BY FUND
 May 24, 2017

Date: 05/19/2017
 Time: 3:07pm
 Page: 5

VILLAGE OF LAKEWOOD

Fund	Department	Account	GL Number	Vendor Name	Check	Invoice	Due	Amount
			Abbrev	Invoice Description	Number	Number	Date	
Fund: Golf Course Fund								
Dept: General & Administrative Dept								
		94-45-8430.000	Computer S	LEADING IT SOLUTIONS Monthly Service	0	21303WC	05/19/2017	77.50
		94-45-8440.000	Telephone	COMCAST Monthly Service- RedTail	0	050517	05/05/2017	234.65
		94-45-8446.000	Water & Se	VILLAGE OF LAKEWOOD RedTail Water/Sewer	0	050817A	05/08/2017	174.40
		94-45-8447.000	Cable TV	COMCAST Monthly Service- RedTail	0	050517	05/05/2017	89.22
		94-45-8456.000	Advertisin	REV TECH PLUS LLC Advertisement May	0	1419	05/01/2017	1,500.00
		94-45-8456.000	Advertisin	GOLF CLUB MASTERS INC Advertisement	0	050117	05/01/2017	497.50
		94-45-8495.000	Dues & Sub	SAM'S CLUB CREDIT Supplies	0	050217	05/02/2017	90.00
Total General & Administrative Dept								3,290.17
Fund Total								24,169.03
Grand Total								345,061.05

Memo

To: Honorable President and Board of Trustees
From: Shannon Andrews, Interim Village Manager
CC: Michael Smoron, Village Attorney
Date: May 19, 2017
Re: Ordinance Granting Variances for 8680 Belfield Road

The Planning & Zoning Commission held a public hearing on May 17, 2017 to consider a variance for the property located at 8680 Belfield Road. This variance would allow for the construction of a masonry privacy wall to extend up to six feet into the front yard of the primary residence. In addition, it would allow for the construction of four accessory structures: a gazebo, a pump house, an equipment house and a bridge over an existing pond. Finally, the roof height of the gazebo would be raised from 15 feet up to 18 feet 6 inches.

The property itself is unique in that it consists of three separate parcels combined into one five acre parcel, which is considerably larger than any of the adjacent lots within the subdivision. As such, the requested accessories are well distributed across the land and are not considered to have an adverse impact on any neighbors. In addition, they do not infringe on any easements or setbacks. All Commissioners present expressed their support of the project as presented and moved in favor of granting the variations.

Staff recommends the Board approve the Ordinance Granting Variances from Sections 7.2-B, 7.4-A and 7.4-B of the Zoning Ordinance Relative to Accessory Structures and a Masonry Privacy Wall for 8680 Belfield Road.

VILLAGE OF LAKEWOOD
PLANNING AND ZONING COMMISSION
PUBLIC HEARING MINUTES
MAY 17, 2017

DRAFT

The meeting was called to order at 7:00 p.m. at RedTail Golf Club. Members present were Chairman John O'Hara; Commissioners Hansen, Hopkins, Knapp, Miller, Morvay, and Mula. Also present were Deputy Village Manager Shannon Andrews, Village Clerk Janice Hansen, Village Attorney Michael Smoron, and the petitioners.

APPROVAL OF MINUTES FROM THE AUGUST 15, 2016 MEETING. Commissioner Hopkins, seconded by Commissioner Hansen, moved to approve the August 15, 2016 minutes. Voice Vote. All Ayes. Nays: None. Motion declared carried.

PUBLIC HEARING: TO CONSIDER A PETITION FROM MICHELLE BETO REVOCABLE TRUST AT 8680 BELFIELD FOR A PROPOSED VARIATION FROM PARAGRAPH B OF SECTION 7.2, LOCATION OF ACCESSORY BUILDINGS, STRUCTURES, AND USES OF THE LAKEWOOD ZONING CODE TO ALLOW A MASONRY PRIVACY WALL, A GAZEBO, A PUMP HOUSE, AN EQUIPMENT HOUSE, AND A BRIDGE:

Village Clerk Janice Hansen confirmed that the public notice was published in the Northwest Herald on March 25, 2017. All neighboring residents were notified by registered mail. All fees have been satisfied to date.

Petitioners Architect Robert Flubacker commented that the existing grading of the property falls away as you move towards the rear yard. This existing change in elevation from the street to the existing pond is down 15 feet. Given this, the proposed structures should be minimally visible from the street and no other structures are in close proximity to these proposed locations.

The property for the proposed three accessory structures were recently consolidated from three separate lots to one parcel. If left as individual lots, a total of three accessory structures would be permitted; one on each lot. The proposed three accessory structures are not increasing the allowed density of accessory structures in the subdivision.

Gazebo accessory structure: the proposed roof height of the Gazebo is 18 feet 6 inches or 3 feet 6 inches above the allowed 15 feet. This roof height is related to the clerestory roof, which has a lower pitch roof and matches the existing house Family Room which has a total peak height of 20 feet 2 inches. The architectural design also maintains an architectural compatibility with the existing house.

Pump House accessory structure: This structure is to contain electric controllers and panels related to existing landscape pumps, aerators and fountains. The hardship comes from these electric controllers and panels need to be installed in an enclosed structure protected from the elements and within a certain maximum distance from the related landscape equipment in the existing pond. The aesthetics has been designed to be compatible with the existing house.

Equipment House accessory structure: This structure is to contain necessary equipment for the maintenance of the property. The hardship addressed is to provide access to required maintenance equipment near the location where it is to be utilized. Without the use of this structure, any needed equipment would have to be continually brought from the house and back each time regular upkeep and maintenance was performed in the northern area of the lot. Taking into account grade elevation differences and landscaping this structure will not be seen from the street.



Bridge Element: The bridge element is a replacement for an existing deteriorating railroad tie bridge. Since the new bridge is not sheltered, it's exposed to the elements and does not provide any habitable space, we view this as a landscape feature and not a true accessory structure. Given the size and location of the existing pond, a crossing bridge at the narrowest point of the pond, near its center, makes the north end of the property much more usable and accessible, as otherwise the owner would have to walk around the entire pond to reach the north end of the property. The replacement of the existing bridge is for safety as well as aesthetics of the property.

Masonry privacy wall (fence): *Location of the fence:* this privacy wall is to be located in the front of the proposed home addition. However, only a portion of this wall will actually encroach (6 feet) into the front yard; that portion in front of the nearest line of the building. This privacy wall does return and become attached to the primary structure and is actually a direct continuation of the house wall and could therefore by definition be considered to be a part of the primary structure and would therefore be allowed as shown without a variance. The intended purpose of this privacy wall and its location in the front yard is to maximize a private outdoor courtyard space for the owner which has access to direct sunlight, as the rear of the house faces north and will never receive the direct sun. By contrast, we could fill this space with a larger enclosed house addition which would be permitted by the code. *Height of fence:* the height of the privacy wall (6 feet 4 inches and 8 feet at the corner piers), as well as the masonry construction is to maintain architectural compatibility with the rest of the house while achieving the desired private courtyard space exposed to direct southern sunlight.

Commissioner Hansen commented that the proposed project is well done, not a detriment to the neighborhood and has no objections.

Commissioner Knapp also had no issues with the proposed project.

Commissioner Miller would like the reference fence changed to masonry wall. All agreed.

Commissioner Hopkins commented on stormwater issues and the possibility of fencing around the pond. No fencing is required around the pond.

Commissioner Mula commented about the location of the equipment house which is not an issue.

Chairman O'Hara asked for confirmation for easement issues, which there are none, and the setback restrictions for the privacy masonry wall, which there are none.

Commissioner Knapp, seconded by Commissioner Miller, moved to close the public hearing. Voice Vote: All Ayes. Nays: None. The public hearing closed at 7:20 p.m.

Commissioner Miller, seconded by Commissioner Hansen, moved to recommend that the petition amending the reference fence to wall be forwarded to the Board of Trustees for approval. Voting Aye: Commissioners Hansen, Hopkins, Knapp, Miller, and Mula and Chairman O'Hara. Voting Nay: None. Absent: Commissioner Morvay. Motion declared carried.

UPDATE ON OTHER PLANNING, ZONING AND DEVELOPMENT ISSUES: Deputy Village Manager Shannon Andrews commented that Taylor Morrison builders for Woodland Hills are proposing

Planning and Zoning Commission
Public Hearing Minutes
May 17, 2017
Page Two of Three

DRAFT

new models. A contractor has expressed interest in obtaining existing lots within Autumn Ridge. Also, a dance studio has expressed interest within Lakewood Commons.

With nothing further to discuss, Commissioner Knapp, seconded by Commissioner Hansen, moved to adjourn the meeting. Voting Aye: Commissioners Hansen, Hopkins, Knapp, Miller, and Mula. Voting Nay: None. Absent: Commissioner Morvay. Motion declared carried. The meeting adjourned at 7:30 p.m.

Janice S. Hansen
Village Clerk

ORDINANCE NO. 2017-(16)

An Ordinance Granting Variances from Sections 7.2-B, 7.4-A and 7.4-B of the Zoning Ordinance of the Village of Lakewood Relative to Accessory Structures and Masonry Privacy Wall for 8680 Belfield Road

WHEREAS, the Village of Lakewood, an Illinois municipal corporation (the "Village"), has received a petition from the Michelle Beto Revocable Trust, the owner of the property (the "Petitioner") commonly known as 8680 Belfield, Lakewood, IL with the following permanent index number and which is legally described as follows:

Lots 5, 6 and 7 in the Reserve of Lakewood, being a subdivision of part of the north half of Section 13, Township 43 North, Range 7 East of the Third Principal Meridian, according to the plat thereof recorded June 16, 2003 as Document No. 2003R0078010 in McHenry County, Illinois (the "Property").

Permanent Index Number 18-13-126-009

WHEREAS, the Property was originally platted as three separate lots;

WHEREAS, a public hearing was conducted by the Lakewood Planning and Zoning Commission (the "Commission"), after due notice in the manner provided by law; and

WHEREAS, after deliberation, the Commission made a recommendation regarding a variation from paragraph B of Section 7.2, LOCATION OF ACCESSORY BUILDINGS, STRUCTURES AND USES, of the Lakewood Zoning Code (the "Code") that the Village allow a masonry privacy wall to extend up to six feet into the front yard (but not in the required front yard setback) of the Property in accordance with the rendering attached hereto as Exhibit A consisting of one page entitled "Beto Residence Proposed Privacy Wall"; a variation from paragraph A of Section 7.4, NUMBER, HEIGHT AND SIZE OF ACCESSORY BUILDINGS AND STRUCTURES, of the Code to allow four accessory structures or uses on the Property, specifically 1) a gazebo, 2) a pump house, 3) equipment house; and 4) a bridge in accordance with those architectural plans prepared by Robert Flubacker Architects Ltd., page A-G.1 dated November 21, 2016, page A-P.1 dated November 21, 2016, page A-E.1 dated February 23, 2017 and page A-1 (with a most recent revision date of February 17, 2017), respectively, project number 1602; and a variation from paragraph B of Section 7.4 of the Code to allow a height of up to 18 feet six inches for the roof height of the gazebo in lieu of the otherwise applicable limit of 15 feet; and

WHEREAS, the Board of Trustees has considered the evidence presented at the public hearing to the Commission by the Petitioner, as well as all of the material that was submitted to the Commission and the minutes reflecting the findings and proceedings of the Commission and hereby makes the following findings of fact:

1. The nature of the variances are unique and not likely to arise under most circumstances;

2. That the variations, if granted, would not alter the essential character of the locality. They would not have any adverse impact on any neighbors, none of whom have objected to this request after notice of same was published in the paper and mailed to those neighbors as required by the Village's Zoning Code;
3. The purpose of the variations are not based upon the desire to increase the value of the property, the monetary gain to be realized from the property, or to alleviate financial difficulty experienced by the Petitioner and the intent is to otherwise comply with the provisions of this Code in all other respects;
4. The granting of the variations will not be detrimental to the public welfare or injurious to other property or improvements in the neighborhood in which the property is located;
5. The proposed variations will not impair an adequate supply of light and air to the adjacent property or substantial increase to congestion in the public streets or increase the danger of fires or danger the public safety, it could substantially diminish or impair property values in the neighborhood.

NOW, THEREFORE, BE IT ORDAINED by the President and Board of Trustees of the Village of Lakewood:

SECTION 1: The Village hereby approves certain variances for the Property as follows:

- i) a variation from paragraph B of Section 7.2, LOCATION OF ACCESSORY BUILDINGS, STRUCTURES AND USES, of the Code to allow a masonry privacy wall to extend up to six feet into the front yard (but not in the required front yard setback) of the Property in accordance with the rendering attached hereto as Exhibit A consisting of one page entitled "Beto Residence Proposed Privacy Wall";
- ii) a variation to allow four accessory structures or uses on the Property, specifically 1) a gazebo, 2) a pump house, 3) equipment house and 4) a bridge in accordance with those architectural plans prepared by Robert Flubacker Architects Ltd., page A-G.1 dated November 21, 2016, page A-P.1 dated November 21, 2016, page A-E.1 dated February 23, 2017 and page A-1 (with a most recent revision date of February 17, 2017), respectively, project number 1602, on file with the Village; and
- iii) a variation from paragraph B of Section 7.4 of the Code to allow a height of up to 18 feet six inches for the roof height of the gazebo in lieu of the otherwise applicable limit of 15 feet.

SECTION 2: Except as provided in this Ordinance, all other requirements set forth in the Lakewood Zoning Code, as would be required by any owner of property zoned in the same manner as the Property, shall be complied with.

SECTION 3: The recommendation of the Planning and Zoning Commission on the question of granting the variations pursuant to the petition are on file in the Village Hall as a part of the official record of the hearing.

SECTION 4: If any section, paragraph, subdivision, clause, sentence or provision of this Ordinance shall be adjudged by any Court of competent jurisdiction to be invalid, such judgment shall not affect, impair, invalidate or nullify the remainder thereof, which remainder shall remain and continue in full force and effect.

SECTION 5: All ordinances or parts of ordinances in conflict herewith are hereby repealed to the extent of such conflict.

SECTION 6: This Ordinance shall be in full force and effect upon its passage and approval. In the event a building permit for this project has not been obtained within six months from the date of passage, this Ordinance shall be considered null and void.

Voting Aye:

Voting Nay:

Absent:

Abstain:

APPROVED:

Village President Mary Erin Smith

(SEAL)

ATTEST: _____
Village Clerk Janice S. Hansen

Passed: _____

Approved: _____

Published: _____

Z:\LAKEWOOD\Ordinances\Beto Variation.docx

EXHIBIT A

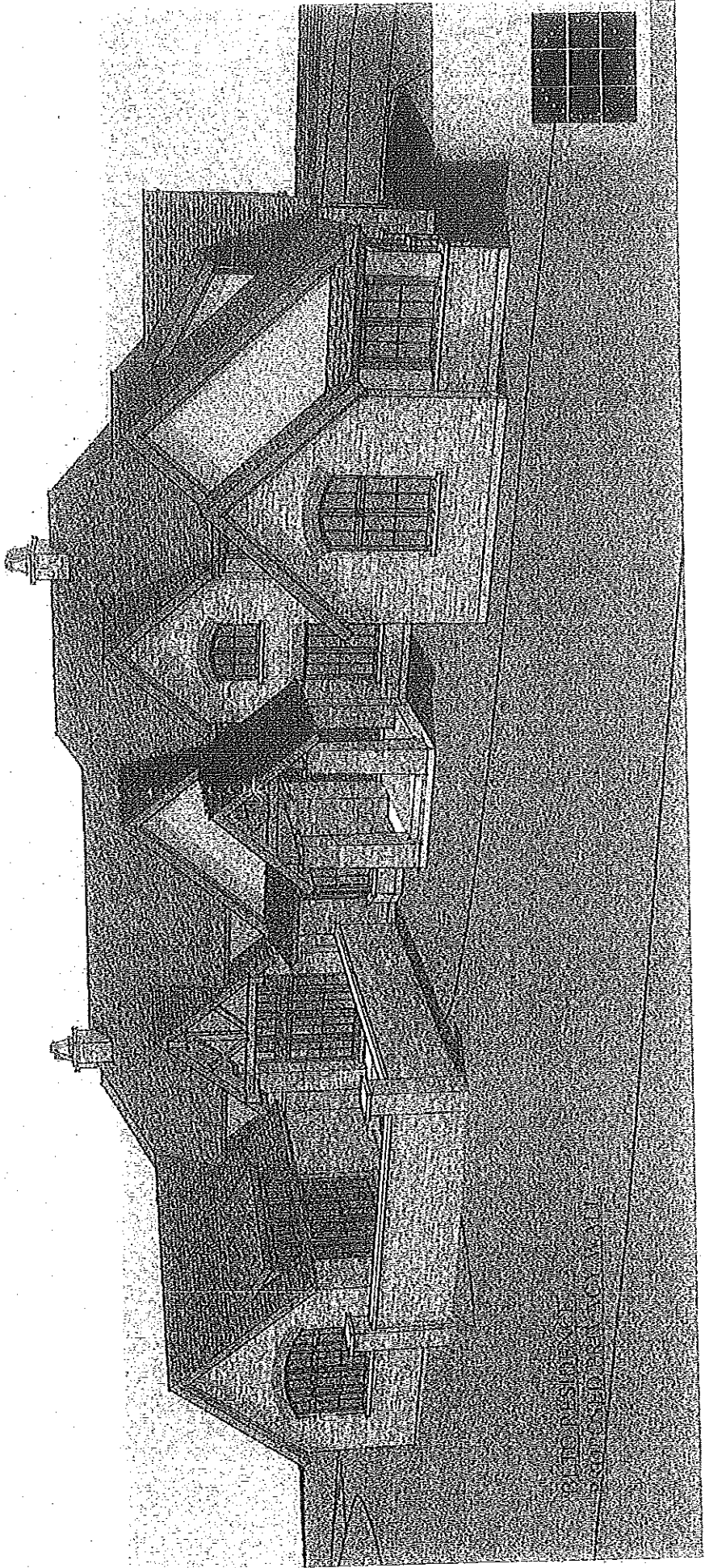

ORDINANCE NO. 2017-(17)
An Ordinance Authorizing the Sale or Disposal
of Personal Property Owned by the Village of Lakewood

WHEREAS, in the opinion of a simple majority of the corporate authorities of the Village of Lakewood, McHenry County, Illinois, it is no longer necessary or useful to or for the best interests of the Village of Lakewood to retain the following described personal property:

2010 Dodge Charger VIN 2B3AA4CV7AH262662
Four (4) Watch Guard Police Squad Video Systems
HP ProLiant ML350G6 Server
Dell Desk Top Dimension 470 Computer
Miscellaneous Dell Desk Top Monitors

now owned by it; and

WHEREAS, 65ILCS 5/11-76-4 authorizes the sale or disposal of said personal property in such manner as the corporate authorities then holding office may designate, with or without advertising the sale.

NOW, THEREFORE, BE IT ORDAINED by the President and Board of Trustees of the Village of Lakewood, McHenry County, Illinois, as follows:

SECTION 1: Pursuant to 65 ILC 5/11-76-4, the President and Board of Trustees find that the following described personal property:

2010 Dodge Charger VIN 2B3AA4CV7AH262662
Four (4) Watch Guard Police Squad Video Systems
HP ProLiant ML350G6 Server
Dell Desk Top Dimension 470 Computer
Miscellaneous Dell Desk Top Monitors

now owned by the Village of Lakewood are no longer necessary or useful to the Village of Lakewood and the best interests of the Village of Lakewood will be served by its sale or disposal.

SECTION 2: Pursuant to 65ILCS 5/11-76-4, the Village Manager be, and is hereby, authorized and directed to sell or dispose of said personal property, with or without advertising the sale.

SECTION 3: If any section, paragraph, subdivision, clause sentence or provision of this Ordinance shall be adjudged by any Court of competent jurisdiction to be invalid, such judgement shall not affect, impair, invalidate or nullify the remainder thereof, which remainder shall remain and continue in full force and effect.

SECTION 4: All ordinances or part of ordinances in conflict herewith are hereby repealed to the extent of such conflict.

SECTION 5: This Ordinance shall be in full force and effect upon its passage, approval and publication in pamphlet form (which publication is hereby authorized) as provided by law.

Voting Aye:

Voting Nay:

Absent:

Abstain:

Approved: _____
President Paul Serwata

(SEAL)

Attest: _____
Village Clerk Janice S. Hansen

Passed:

Approved:

Published:

Memo

To: Honorable President and Board of Trustees
 From: Shannon Andrews, Interim Village Manager
 CC: Michael Smoron, Village Attorney
 Date: May 19, 2017
 Re: Truck Purchase

As was discussed at the March 14, 2017 budget workshop, the fiscal year 2017/2018 budget included an expenditure of \$189,500 for the purchase of a replacement plow truck. Attached for your review is a quote from Rush Truck Centers in the amount of \$177,428, which is \$12,072 under the budgeted amount. This quote is for a 2018 International, Series 7400 SBA 4x2, with the truck chassis (\$89,103) provided by Rush Truck Centers and the body equipment (\$88,325) provided by Henderson of Illinois. The Sales Order and detailed specifications have been attached for your review.

While it had been originally approved with the full expenditure coming from the general fund, an alternative to this would be to draw the funds from Impact Fee Fund. This would allow for the general fund to maintain a minimum six month reserve threshold.

At the May 9, 2017 meeting, the Board discussed the concept of leasing versus purchasing the equipment. The members present were uncomfortable with the additional \$18,612.05 to lease the equipment and the option was removed from consideration. The Board tabled the agenda item for the purchase to allow for a meeting between Village staff and an informal committee of residents with backgrounds related to public works. A recommendation was made to pursue an additional bid through Peterbuilt in Wadsworth, which has been attached for your review. Staff sought a third quote from Western Star (also attached) and a summary of the results of all three chassis bids has been provided below:

Rush	\$89,103	
Peterbuilt	\$89,996	(\$88,496 base w/ warranties + \$1,500 for Add'l Framework)
Western Star	\$91,237	

In the event of a breakdown during a snow event, Rush Truck Centers is just minutes away in Huntley. Their close proximity for parts or service regularly saves on staff time, but can be critical during a snow event when the truck needs to be serviced and back on the street as soon as possible.

The following additional recommendations were made from one of the group members:

- Purchase a rubber blade instead of carbide. Rubber blades with steel backing are quieter and may help to preserve the roadway, however the rubber wears away quickly and exposes the steel within. These blades require a significant amount of maintenance as they need regular adjustments and replacement on an annual basis. Due to our very limited staff and budget, the rubber blades are not currently being recommended.
- Purchase an additional insurance policy that would cover the cost of removing the insert and reinstalling it into the original equipment. Staff is comfortable with the warranties provided as part of the bid. In addition, the insert for the new plow would not be compatible to the old truck, so this option would not be viable for our limited fleet.
- As a preventative maintenance measure, consider full replacement of the hoses on an annual basis. In response to a hose failure in the 2015-2016 season that took our truck out of service for a number of hours, our public works staff recommended the purchase of new hoses for all of the trucks. Instead of purchasing new each year, staff has retained the ones replaced. Despite their age, they are still viable and can serve as emergency replacements. The new truck is outfitted with stainless steel hoses, which should have an extended life span.

Outside of consideration of the above recommendations, my understanding is that each group member has individually indicated support for the purchase as recommended.

Staff recommends the Board approve a motion for the purchase of the 2018 International Series 7400 SBA 4x2 Truck in the amount of \$177,428 from Rush Truck Centers.



Rush Truck Center, Springfield
 401 S. Dirksen Parkway
 Springfield, IL 62703-2106
 (217) 523-5631

Retail Sales Order

rushtruckcenters.com

1. Parties to Order; Definitions. As used in this Retail Sales Order ("Order"), the terms: (a) "Dealer" shall mean the Rush Dealer identified at the top of the first page of this Order; (b) "Customer" shall mean the Customer identified on the first page of this Order; (c) "Manufacturer(s)" shall mean the entity or entities that manufactured the Product(s), it being understood by Customer that Dealer is in no respect the agent of Manufacturer(s); and (d) "Product(s)" shall mean the new and/or used vehicle or other components, accessories or products, which are being purchased by Customer, as set forth in this Order.

2. WARRANTY DISCLAIMERS AND LIMITATIONS

NEW PRODUCTS - MANUFACTURER WARRANTIES ONLY. Any warranties on any new Product(s) sold under this Order are limited only to any printed Manufacturers' warranties delivered to Customer with the Product(s). EXCEPT FOR ANY SUCH WARRANTIES MADE BY MANUFACTURERS, THE PRODUCT(S) ARE SOLD WITHOUT ANY OTHER WARRANTIES, EXPRESS OR IMPLIED, INCLUDING ANY IMPLIED WARRANTY OF MERCHANTABILITY OR FITNESS FOR A PARTICULAR PURPOSE, EACH OF WHICH IS EXPRESSLY DISCLAIMED.

USED PRODUCTS - NO WARRANTIES. All used Product(s) sold under this Order are sold on an "AS IS, WHERE IS" basis, without any warranties by Dealer, provided that Products that are sold by Dealer as "Certified Pre-Owned" are subject to the express written terms and conditions of the Dealer's certified pre-owned program. EXCEPT FOR ANY MANUFACTURERS' WARRANTIES THAT MAY STILL BE IN EFFECT, ALL OTHER WARRANTIES, EXPRESS OR IMPLIED, INCLUDING ANY IMPLIED WARRANTY OF MERCHANTABILITY OR FITNESS FOR A PARTICULAR PURPOSE, ARE EXPRESSLY DISCLAIMED.

LIMITED WARRANTY ON SERVICES. Dealer warrants that all services performed by Dealer for Customer in conjunction with the sale of the Product(s), including if applicable installation, upfitting and conversion services ("Services"), will be performed in a good and workmanlike manner ("Services Warranty"). The Services Warranty is valid for a period of ninety (90) days from the date the Product(s) is delivered to Customer. Customer's sole and exclusive remedy, and Dealer's entire liability, under the Services Warranty is the repair of any nonconforming portion of the Services. DEALER PROVIDES NO OTHER WARRANTIES, EXPRESS OR IMPLIED, CONCERNING ITS SERVICES. The Services Warranty is strictly limited to Services performed by Dealer for Customer. Dealer does not warrant any services provided by any third-party, including but not limited to installation, upfitting or conversion services. Any warranties are solely those that are provided by the third-party service provider.

NO OTHER WARRANTIES. EXCEPT AS SET FORTH ABOVE, DEALER EXPRESSLY DISCLAIMS ALL WARRANTIES, EXPRESS OR IMPLIED.

3. Reappraisal of Trade-In Vehicle. If the motor vehicle which has been traded in ("Trade-In Vehicle") as a part of the consideration for the Product(s) ordered hereunder is not to be delivered to Dealer until delivery to Customer of the Product(s), the Trade-In Vehicle shall be reappraised at that time and such reappraised value shall determine the allowance made for the Trade-In Vehicle. If the reappraised value is lower than the original allowance shown on the front of this Order, Customer may, if dissatisfied, cancel this Order.

4. Delivery of Trade-In Vehicle by Customer; Customer Warranty of Title. Customer agrees to deliver to Dealer satisfactory evidence of title to the Trade-In Vehicle at the time of delivery of the Trade-In Vehicle to Dealer. Customer warrants the Trade-In Vehicle to be Customer's property free and clear of all liens and encumbrances.

5. Delay or Failure in Delivery; Limitation of Dealer Liability. Dealer shall not be liable for failure to deliver or delay in delivering any Product(s) covered by this Order where such failure or delay is due, in whole or in part, to any cause beyond the reasonable control, or is without the gross negligence or intentional misconduct, of Dealer. Examples of causes beyond Dealer's reasonable control include, but are not limited to, Manufacturers' delay or failure to deliver Product(s) for any reason, earthquake, hurricane or other natural disaster, fire, war, terrorist act, labor dispute, strike, etc.

6. Liability for Taxes. The price for the Product(s) specified on the face of this Order includes reimbursement to Dealer for federal excise taxes paid, but does not include sales or use taxes or occupational taxes based on sales volume (federal, state or local) unless expressly so stated. Customer assumes and agrees to pay, unless prohibited by law, any such sales or use or occupational taxes imposed on or applicable to the transaction covered by this Order, regardless of which party may have primary tax liability thereof.

7. Customer's Deposit. Any Customer's deposit, whether cash or Trade-In Vehicle, shall not be refunded except due to Dealer's failure to deliver the Product(s).

8. Risk of Loss; Insurance. Customer shall assume all risk of loss relating to the Product(s) at the time Customer receives possession of the Product(s), or at the time Customer receives title to the Product(s) if title is conveyed before Customer receives possession. Customer shall obtain insurance for the Product(s) that will be in effect at the time Customer takes possession of the Product(s), or at the time Customer receives title to the Product(s) if title is conveyed before the Customer receives possession. Dealer shall have no responsibility or liability related to the Product(s) after Customer receives either possession or title to the Product(s).

9. Governing Law; Venue; Time to Commence Action. Except to the extent that the laws of the United States may apply or otherwise control this Order, the rights and obligations of the parties hereunder shall be governed by, and construed and interpreted in accordance with, the laws of the state in which Dealer is located, without regard to conflict of law principles. The mandatory venue for any claim, litigation, civil action or any other legal or administrative proceeding ("Action") involving any controversy or claim between or among the parties to this Order, is the state in which Dealer is located. Customer has one (1) year from the accrual of any cause of action arising from the purchase of the Product(s) to commence an Action against Dealer.

10. Limitation of Damages. Customer agrees that in the event of any Action brought by Customer against Dealer, Customer shall not be entitled to recover any incidental or consequential damages as defined in the Uniform Commercial Code, including but not limited to indirect or special damages, loss of income or anticipated profits, or down-time, or any punitive damages.

11. Fees and Expenses of Actions. In any Action, whether initiated by Dealer or Customer, where the Customer has a right, pursuant to statute, common law or otherwise, to recover reasonable attorneys' fees and costs in the event it prevails, Customer agrees that Dealer shall have the same right to recover reasonable attorneys' fees and costs incurred in connection with the Action in the event that Dealer prevails.

12. Execution and Delivery by Electronic Transmission. If this Order or any document executed in connection with this Order is delivered by facsimile, email or similar instantaneous electronic transmission device pursuant to which the signature of or on behalf of such party can be seen, such execution and delivery shall be considered valid, binding and effective for all purposes as an original document. Additionally, the signature of any party on this Order transmitted by way of a facsimile machine or email shall be considered for all purposes as an original signature. Any such faxed or emailed document shall be considered to have the same binding legal effect as an original document. At the request of Dealer, any faxed or emailed document shall be re-executed by Customer in an original form.

13. Waiver; Severability. No waiver of any term of this Order shall be valid unless it is in writing and signed by Dealer's authorized representative. If any provision or part of any provision of this Order shall be deemed to violate any applicable law or regulation, such invalid provision or part of a provision shall be inapplicable, BUT the remaining part of that provision and the remainder of the Order shall continue to be binding and enforceable.

14. No Broker; Manufacturer Incentives. If at any time Dealer determines that the Customer intends to engage in the resale of vehicles for profit, where such resale is not in conjunction with further manufacturing, Dealer reserves the right to cancel this Order. Certain manufacturer incentives are intended to be used for retail customers at the location as identified by the Customer in this Order. Customer represents that they will register the vehicle with their state motor vehicle department and are not purchasing this vehicle with the intent to resell/export the vehicle, except where such resale is in conjunction with further manufacturing. If at any time Dealer determines that the foregoing representations are not true, Dealer has the right to seek repayment of any manufacturer incentives that are paid.

15. Communication Consent. Dealer and any other owner or sender of this account may use any information Customer gives Dealer, including but not limited to email addresses, cell phone numbers, and landline numbers, to contact Customer for purposes related to this account, including debt collection and marketing purposes. In addition, Customer expressly consents to any such contact being made by the most efficient technology available, including but not limited to, automated dialing equipment, automated messages, and prerecorded messages, even if Customer is charged for the contact.

Customer Initial _____

Prepared For:
 Village of Lakewood
 Barry Wickersheim
 6570 Haligus Rd.
 Crystal Lake, IL 60014-6628
 (815)459 - 3025
 Reference ID: Updated 2017

Presented By:
 RUSH TRK CTR OF N IL
 David R Mueller
 11816 S IL RTE 47
 HUNTLEY IL 60142 -
 (847)669-5700

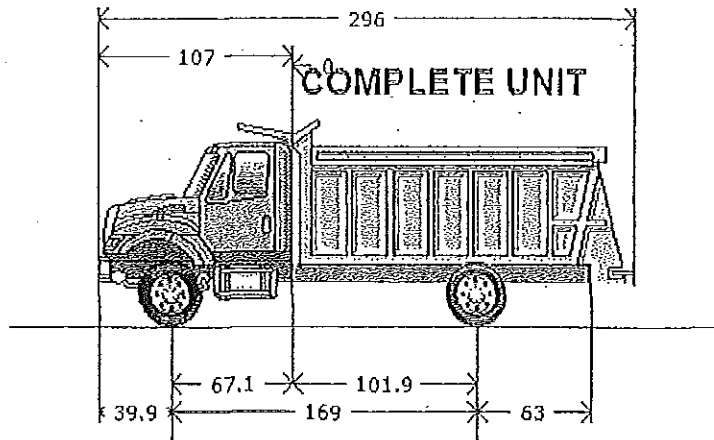

Model Profile
 2018 7400 SBA 4X2 (SA625)

MISSION:	Requested GVWR: 35000. Calc. GVWR: 41000
DIMENSION:	Wheelbase: 169.00, CA: 101.90, Axle to Frame: 63.00
ENGINE, DIESEL:	{Navistar N9} EPA 2010, SCR, 330 HP @ 2000 RPM, 950 lb-ft Torque @ 1200 RPM, 2200 RPM Governed Speed, 330 Peak HP (Max)
TRANSMISSION, AUTOMATIC:	{Allison 3000_RDS_P} 5th Generation Controls; Close Ratio, 6-Speed, with Double Overdrive; On/Off Hwy; Includes Oil Level Sensor, with PTO Provision, Less Retarder, with 80,000-lb GVW & GCW Max.
CLUTCH:	Omit Item (Clutch & Control)
AXLE, FRONT NON-DRIVING:	{Meritor MFS-18-133A} Wide Track, I-Beam Type, 18,000-lb Capacity
AXLE, REAR, SINGLE:	{Meritor RS-23-160} Single Reduction, 23,000-lb Capacity, With 200 Wheel Ends Gear Ratio: 6.83
CAB:	Conventional
TIRE, FRONT:	(2) 315/80R22.5 Load Range L UNISTEEL G291 (GOODYEAR), 491 rev/mile, 68 MPH, All-Position
TIRE, REAR:	(4) 11R22.5 Load Range G G622 RSD (GOODYEAR), 497 rev/mile, 75 MPH, Drive
SUSPENSION, RR, SPRING, SINGLE:	Vari-Rate; 31,000-lb Capacity, Includes 4500-lb Capacity Multileaf Auxiliary
PAINT:	Cab schematic 100GN Location 1: 4421, School Bus Yellow (Std) Chassis schematic N/A

Description

2-WAY RADIO Wiring Effects; Wiring with 20 Amp Fuse Protection, Includes Ignition Wire with 5 Amp Fuse, Wire Ends Heat Shrink and Routed to Center of Header Console in Cab

RADIO AM/FM/WB/Clock/3MM Auxiliary Input, with Multiple Speakers

AUXILIARY HARNESS 3.0' for Auxiliary Front Head Lights and Turn Signals for Front Plow Applications

TRAILER CONNECTION SOCKET 7-Way; Mounted at Rear of Frame, Wired for Turn Signals Combined with Stop, Compatible with Trailers That Use Combined Stop, Tail, Turn Lamps

HORN, ELECTRIC Disc Style

BATTERY BOX Aluminum, with Plastic Cover; Mounted 35" Back of Cab, Right Side Perpendicular to Frame Rail

SWITCH, BODY CIRCUITS, MID for Bodybuilder, 6 Momentary Switches in Instrument Panel; One Power Module with 6 Channels; 20 Amp Max. Per Channel, 80 Amp Max Output, Switches Control Power Module Through Multiplex Wiring, Mounted in Cab Behind Driver Seat

JUMP START STUD Remote Mounted

HORN, AIR Black, Single Trumpet, Air Solenoid Operated

CLEARANCE/MARKER LIGHTS (5) (Truck Lite) Amber LED Lights, Flush Mounted on Cab or Sunshade

STARTING MOTOR (Delco Remy 38MT Type 300) 12 Volt; less Thermal Over-Crank Protection

INDICATOR, LOW COOLANT LEVEL with Audible Alarm

CIRCUIT BREAKERS Manual-Reset (Main Panel) SAE Type III with Trip Indicators, Replaces All Fuses Except For 5-Amp Fuses

TURN SIGNALS, FRONT Includes LED Side Turn Lights Mounted on Fender

FENDER EXTENSIONS Rubber

INSULATION, UNDER HOOD for Sound Abatement

GRILLE Stationary, Chrome

INSULATION, SPLASH PANELS for Sound Abatement

FRONT END Tinting, Fiberglass, with Three Piece Construction; for WorkStar

PAINT SCHEMATIC, PT-1 Single Color, Design 100

PAINT TYPE Base Coat/Clear Coat, 1-2 Tone

VEHICLE REGISTRATION IDENTITY ID for 49 States, Excluding California

CLUTCH Omit Item (Clutch & Control)

ANTI-FREEZE Red, Extended Life Coolant; To -40 Degrees F/ -40 Degrees C, Freeze Protection

ENGINE, DIESEL (Navistar N9) EPA 2010, SCR, 330 HP @ 2000 RPM, 950 lb-ft Torque @ 1200 RPM, 2200 RPM Governed Speed, 330 Peak HP (Max)

FAN DRIVE (Horton Drivemaster Polar Extreme) Direct Drive Type, Two Speed, with Residual Torque Device for Disengaged Fan Speed

RADIATOR Aluminum, Cross Flow, Series System; 1228 SqIn Core and 648 SqIn Charge Air Cooler

AIR CLEANER Single Element, with Integral Snow Valve and In-Cab Control

FEDERAL EMISSIONS (Navistar N9 & N10) EPA, OBD and GHG Certified for Calendar Year 2017

THROTTLE, HAND CONTROL Engine Speed Control; Electronic, Stationary, Variable Speed; Mounted on Steering Wheel

ENGINE CONTROL, REMOTE MOUNTED Provision for; Includes Wiring for Body Builder Installation of PTO Controls; with Ignition Switch Control for MaxxFORCE and Navistar post 2007 Emissions Electronic Engines

EMISSION COMPLIANCE Federal, Does Not Comply with California Clean Air Idle Regulations

Description

TRANSMISSION, AUTOMATIC (Allison 3000_RDS_P) 5th Generation Controls; Close Ratio, 6-Speed, with Double Overdrive; On/Off Hwy; Includes Oil Level Sensor, with PTO Provision, Less Retarder, with 80,000-lb GVW & GCW Max.

OIL COOLER, AUTO TRANSMISSION (Modine) Water to Oil Type

TRANSMISSION DIPSTICK Relocated to Right Side of Transmission

TRANSMISSION OIL Synthetic; 29 thru 42 Pints

ALLISON SPARE INPUT/OUTPUT for Rugged Duty Series (RDS); General Purpose Trucks, Construction

TRANSMISSION SHIFT CONTROL (Allison) Bump Shifter Type; for Allison 3000 & 4000 Transmission

TRANSMISSION TCM LOCATION Located Inside Cab

SHIFT CONTROL PARAMETERS Allison 3000 or 4000 Series Transmissions, 5th Generation Controls, Performance Programming

PTO LOCATION Dual, Left and Right Side of Transmission

AXLE, REAR, SINGLE (Meritor RS-23-160) Single Reduction, 23,000-lb Capacity, With 200 Wheel Ends . Gear Ratio: 6.83

SUSPENSION, RR, SPRING, SINGLE Vari-Rate; 31,000-lb Capacity, Includes 4500-lb Capacity Multileaf Auxillary

FUEL TANK STRAPS Bright Finish Stainless Steel

FUEL/WATER SEPARATOR with Thermostatic Fuel Temperature Controlled Electric Heater, and Filter Restriction/Change Indicator, Includes Standard Equipment Water-in-Fuel Sensor

FUEL TANK Top Draw; D-Style, Non-Polished Aluminum, 19" Deep, 70 U.S. Gal., 265 L-Capacity, with Quick Connect Outlet, Mounted Left Side, Under Cab

DEF TANK 7 U.S. Gal. 26.5L Capacity, Frame Mounted Outside Left Rail, Under Cab

CAB Conventional

GAUGE CLUSTER English with English Electronic Speedometer

GAUGE, OIL TEMP, AUTO TRANS , for Allison Transmission

GAUGE, AIR CLEANER RESTRICTION (Filter-Minder) with Black Bezel Mounted in Instrument Panel

IP CLUSTER DISPLAY On Board Diagnostics Display of Fault Codes in Gauge Cluster

GAUGE, DEF FLUID LEVEL

SEAT, DRIVER (National 2000) Air Suspension, High Back with Integral Headrest, Vinyl, Isolator, 1 Chamber Lumbar, with 2 Position Front Cushion Adjust, -3 to +14 Degree Angle Back Adjust

SEAT, PASSENGER (National) Non Suspension, High Back with Integral Headrest, Vinyl, with Fixed Back, with Under Seat Storage

GRAB HANDLE Chrome; Towel Bar Type with Anti-Slip Rubber Inserts; for Cab Entry Mounted Left Side Only at "B" Pillar

MIRRORS (2) (Lang Mekra) Rectangular, Thermostatically Controlled Heated Heads, Bright Finish Heads, with Black Brackets and Arms, Breakaway Type, 7.55" x 14.1" Integral Convex Both Sides, 102" Inside Spacing,

ARM REST, RIGHT, DRIVER SEAT

AIR CONDITIONER (Blend-Air) with Integral Heater & Defroster

INSTRUMENT PANEL Center Section, Flat Panel

HVAC FRESH AIR FILTER

CAB INTERIOR TRIM Deluxe

CAB REAR SUSPENSION Air Bag Type

WINDSHIELD WIPER BLADES Snow Type

Description

COWL TRAY LID

WHEELS, FRONT (Accuride 41730) DISC; 22.5x9.00 Rims, Standard Polish Aluminum, 10-Stud, 285.75mm BC, Hub-Piloted, Flanged Nut, with Steel Hubs

WHEELS, REAR DUAL DISC; 22.5x8.25 Rims, Non-Polished Aluminum, 10-Stud 285.75mm BC, Hub-Piloted, Flanged Nut, with Steel Hubs

(4) TIRE, REAR 11R22.5 Load Range G G622 RSD (GOODYEAR), 497 rev/mile, 75 MPH, Drive

(2) TIRE, FRONT 315/80R22.5 Load Range L UNISTEEL G291 (GOODYEAR), 491 rev/mile, 68 MPH, All-Position

Cab schematic 100GN

Location 1: 4421, School Bus Yellow (Std)

Chassis schematic N/A

Services Section:

WARRANTY Standard for WorkStar 7300/7400 (4x2, 4x4, 6x4, 6x6), Effective with Vehicles Built January 2, 2015 or Later, CTS-2002U

SRV CONT, EXT AFTERTREATMENT (Navistar) To 84-Month/100,000 Miles (160,000 km), 3,600 Hours; Aftertreatment Coverage for MaxxFord DT, MaxxFord 9, and Navistar N9 Engines

SRV CONTRACT, EXT ENGINE (Navistar) To 84-Month/100,000 Miles (160,000 km), 3,600 Hours; Includes Engine, Engine Electronics and Injectors; for MaxxFord 9 and Navistar N9 Engines

SRV CONTRACT, EXT HTR/AC SYS (Navistar Prepackaged Components) To 60-Month/50,000 Miles (80,000 km)

SRV CONTRACT, EXT ELECTRICAL (Navistar Prepackaged Components) Excludes Starter and Alternator, To 60-Month/50,000 Miles (80,000 km)

ALLISON 2 YEAR EXTENDED WARRANTY (for total of 5 years)

HENDERSON QUOTE DATED 04-07-2017

Note: Body is NOT Painted Yellow to Match Cab



Henderson Products - Illinois
11921 Smith Drive
Huntley, IL. 61042

Toll Free: 888-360-7483
Office: 847-836-4996

Quote

Date: 4/7/17
To: Barry at Village of Lakewood
By: Joe Vagle
Re: New Single Axle

Henderson Truck Equipment-Illinois is pleased to quote the following equipment:

(1) Henderson MKESA Single Axle Dump

10' long x 30" high sides with a 38" tailgate
Double v-cripped side braces
10 gauge 201 stainless steel sides and ends
10 gauge 201 sloped side boards bolt in
Side boards are to be bolted into board pockets
1/4" AR400 floor
Air Tailgate using a double acting air cylinder
Switch for air tailgate to be installed in OEM switch panel
Fold down ladder w/ grab handle drivers side front corner
SS grip strut walk rail on each side
Double acting under-body scissor hoist system, grease-able
Two 6" lightholes in each rear corner post
Top hole to have amber/white split LED warning lights installed
Bottom hole to have red LED stop/tail/turn with white back up light installed
22" x 86" cabshield with integral full width light box installed with the following lights
Two LED amber warning lights facing forward, one per side
Two LED amber warning lights facing the side, one per side
Two LED amber warning lights facing rearward, one per side
Two LED red stop/tail/turn lights facing rearward, one per side
US Tarps manual tarp system with asphalt rated tarp
Tarp to be installed in aluminum tarp housing
Swinging mudflap brackets installed at rear
Spring loaded SS shovel holder

(1) Henderson RSP Reversible Snowplow

12' long x 48" tall **WITHOUT** integral shield
Full trip with two compression trip springs
Dual 4" x 10" double acting reversing cylinders
Tubular push frame
Pin and loop style coupler system, plow portion quick attach
Rubber snow deflector with stainless steel backer bar
36" plastic side markers
Parking jack
Carbide cutting edges

(1) Henderson HCH Snowplow Hitch

Pin and Loop style coupler hitch design
4" x 2" Double acting lift cylinder
1/2" thick side plates with 5/8" front push plate - *IDC-IL standard installation*
Powder coat painted

Remove cushion valve from plow and installed on drivers side cheek plate below bumper
Install QD's for plow reversing only - Hard plumb lift cylinder
Install pressure release valve in plow reversing circuit

(1) Henderson PWS Pre-Wetting System

Dual 120 gallon reservoirs installed behind the cab
Hydraulic powered pump
10 gpm hydraulic pump
Micro-Trak turbine style flow meter
System flush kit with 2-1/2 gallon reservoir
Install reservoir above pre-wet pump enclosure
Use Banjo 3 way ball valve
Mark banjo fitting "P" for pre-wet and "F" for flush on yellow handle
2" male quick fill w/ cap
Install below pre-wet reservoir on drivers side of truck
Plumbed to Slurry tube installed inside TGS spreader
Use cam lock fitting near hydraulic quick disconnects for easy removal

(1) Henderson HWS Front Mounted Wing System

9' long x 32" tall grade 50 moldboard
18" front lifting height
Hydraulically extendable rear push arm
Removable facaplate style rear mounting
Hydraulic quick disconnects front and rear

(1) Force America Central Hydraulic System

Ultra armrest with three electric joysticks for hoist/plow/wing
Top button on wing joystick wired to operate wing extension function
Seat mounting bracket
SS5100EX spreader controller
Install spreader controller off armrest w/ bracket
TXV load sensing hydraulic pump
Hot shift PTO
Stainless steel hydraulic reservoir/valve enclosure combination
Add-A-Fold hydraulic valve assembly for:
 Double acting hoist
 Double acting plow up/down
 Double acting wing heel
 Double acting wing toe
 Double acting wing extend
 Auger
 Spinner
 Pre-wetting
Stainless steel hydraulic tubing to rear of the truck
Hydraulic hoses, fitting, fluid as required to complete the system
Temp/level sender unit
Plow pressure release valve
RoadWatch pavement temperature sensor

(1) Electrical and Lighting Package

Back up alarm - IDC IL standard installation location
Body up light - *Install using light in Force America 5100EX control head*
Hella Snowplow lights installed on stainless steel brackets on the hood of the truck
IDC IL standard installation location
Plow lights wired to OEM dash switch
Two LED work lights, one per side at rear
Install one on each side outside of corner post
Wire passenger side light to be used as a back up light
One LED work light installed on passenger side cab entry step for use with wing, wired to separate switch
7 pole RV trailer plug - *Contact customer for wiring instructions*
Electric brake controller
Two ABL LED long range work lights installed forward facing in cabshield

Use Henderson Power Plus wiring panel

(1) Misc Equipment

One set of mudflaps installed behind rear wheels on swinging brackets

Install brackets forward of the rear corner posts

Mudflaps to be 36" length

One set of poly 1/4 fenders installed in front of rear wheels

3/4" pintle plate installed at rear of truck

20 ton bolt on pintle hook - *Set at 24" from ground to seat of pintle hook*

Two "D" rings on pintle plate - *See pictures for pintle plate layout*

(1) Henderson TGS Under-Tailgate Spreader

6" direct drive auger

201 stainless steel construction

Sensored auger motor

18" poly spinner disc

Stainless steel mounting hardware

1/2" stainless steel pre-wet application tube

OPTIONAL EQUIPMENT

None

~~Paint color is steel body yellow to match the cab~~

NOTES:

Cab to axle dimension required is 102"

Delivery is 60 days after receipt of chassis

Price per Unit:	\$88,325.00
Number of Units	1
Extended Price	\$88,325.00
Tax	
Total Quote Price	\$88,325.00

FOB Huntley, IL

Please note the following regarding installation quotes:

A clean truck frame without obstruction is assumed in the pricing of our quote. Re-positioning of air tanks, fuel tanks or other obstacles to the ease of installation may require additional charges. Henderson will notify you before modification if this occurs.

Notice Regarding Security Interest and Payment of Purchase Price

1. BMO Harris Bank N.A. ("Bank") financed or will finance the acquisition of each vehicle that Rush Enterprises, Inc. and its subsidiaries ("Rush") will in turn sell to you on deferred payment terms ("Vehicle"). Bank's agreement with Rush requires that Bank's security interest in each Vehicle continue until Bank receives the full amount that Bank financed for such Vehicle. Based on that agreement, your purchase of a Vehicle will be subject to Bank's prior, unrelinquished security interest, which will continue until Bank receives the total amount that Bank financed for such Vehicle.
2. By written notice to you, Bank may require you to pay the purchase price for Vehicles directly to Bank. If you pay any portion of the purchase price for a Vehicle directly to Bank, Rush will credit such payment(s) against the amount you owe to Rush.



42400 Hwy 41 – Wadsworth, IL. - 60083



NJPA CONTRACT 081716-PMC

Date: 5-15-2017
To: Village of Lakewood
2500 Lake Ave
Lakewood, IL. 60014
Barry

Dear Barry,
We are pleased to quote the following Peterbilt Cab and Chassis

(1) 2018 Peterbilt Model 348 Cab and Chassis as per the attached Specifications

ADDED:

Painted Aluminum Air Tanks

Battery Dis Connect Switch

School Bus Yellow Paint

TOTAL \$ 85,257.00

Warranty OPTIONS:

5 year / 100K miles engine and after treatment \$ 2,750.00

5 Year Allison Transmission Warranty \$ 489.00

Plates and Title fees included

**** **Payment due at time of delivery to Henderson** ****

(No Additional Body Company Floor Plan Included)

Rick Michalowski | Vocational Account Manager

JX Enterprises, Inc.

Cell 708-207-2354 | Fax 708-460-8991

rmichalowski@jxe.com

www.JXE.com

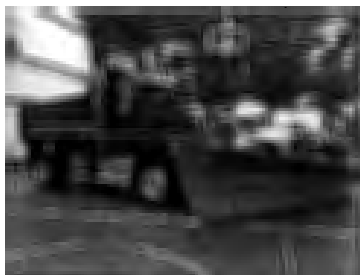

PETERBILT

JX Peterbilt - Bolingbrook P128
535 E South Frontage Rd

Village of Lakewood

Bolingbrook, Illinois United States 60440
Phone: (630) 972-2720
Fax: (630) 972-2721
Email: rmichalowski@jxe.com

Phone: (815) 509-8044
Fax:
Contact Email:
Prepared for: Barry

Vehicle Summary

Unit		Chassis	
Model:	Model 348	Fr Axle Load (lbs):	20000
Type:	Full Truck	Rr Axle Load (lbs)	23000
Description:	Plow Truck	G.C.W. (lbs):	43000
Application		Road Conditions:	
Intended Serv.:	Snowplow	Class A (Highway)	100
Commodity:	Other Commodity	Class B (Hwy/Mtn)	0
Body		Class C (Off-Hwy)	0
Type:	End Dump	Class D (Off-Road)	0
Length (ft):	10	Maximum Grade:	6
Height (ft):	13.5	Wheelbase (in):	172
Max Laden Weight (lbs):	1000	Overhang (in):	60
Trailer		Fr Axle to BOC (in):	69.8
No. of Trailer Axles:	0	Cab to Axle (in):	102.2
Type:		Cab to EOF (in):	162.2
Length (ft):	0	Overall Comb. Length (in):	298
Height (ft):	0.0	Special Req.	
Kingpin Inset (in):	0	United States Registry	
Corner Radius (in):	0		
Restrictions			
Length (ft):	40		
Width (in):	102		
Height (ft):	13.5		

Approved by: _____ Date: _____

Note: All sales are F.O.B. designated plant of manufacture.

	PacLease can help control costs and eliminate the challenges of owning, operating and maintaining your truck fleet. - Improve Operations - Preserve Capital for Growth - Stay Focused on Your Business Contact PacLease for a quote today, or visit our website @ www.paclease.com .
--	---

Unpublished options may require review/approval.
Dimensional and performance data for unpublished options may vary from that displayed in PROSPECTOR.

Printed:	5/15/2017 12:47:51 PM	Complete	Model Number:	Model 348
Effective Date:	Jan 1, 2017		Quote/DTPO/CO:	Q84612360
Prepared by:	Rick M Michalowski		Version Number:	34.20

PETERBILT

JX Peterbilt - Bolingbrook P128
535 E South Frontage Rd

Village of Lakewood

Bolingbrook, Illinois United States 60440

Phone: (630) 972-2720

Fax: (630) 972-2721

Email: rmichalowski@jxe.com

Phone: (815) 509-8044

Fax:

Contact Email:

Prepared for: Barry

Data	Code	Description	\$ List	Weight
Base Model				
0003481	O	Model 348	101,350	10,610
0091200	O	Other Commodity	0	0
0093150	O	Snowplow Truck which is configured for mounting a snowplow to the front. May also have dump or other body.	0	0
0095170	O	End Dump	0	0
0098170	O	United States Registry	0	0
Configuration				
0200700	O	Not Applicable Secondary Manufacturer	0	0
Frame & Equipment				
0514000	O	10-3/4in Steel Rails To 354in 10.75x3.5x.375 Dimension, 2,136,000 RBM; Yield Strength: 120,000 psi. Section Modulus: 17.8 cubic inches. Weight: 1.74 lbs/inch pair	615	357
0612230	O	Custom Wheelbase or Overhang Engineering approval may be required.	365	0
0613090	S	Three-Piece Crossmembers	0	0
0620580	O	27.8in Bumper Extension without Adapter Includes Stationary Grille. Requires FEPTO Bumper.	362	0
0644090	S	EOF Square without Xmbr For use with body builder installed crossmember.	0	0
0651090	S	Omit Rear Mudflaps and Hangers	0	0
Front Axle & Equipment				
1012200	O	Meritor MFS20 20,000 lb, 3.74 in Drop	1,378	163
1114030	O	Taper Leaf Springs, Shocks 20,000 lb Standard with Heavy Resistance Shocks.	1,317	119
1243050	O	Power Steering Sheppard HD94 Dual For use with 16,000 to 20,000 lb. axle ratings.	809	0
1250250	O	Power Steering Reservoir Frame Mounted w/Cooler	154	2
1354790	O	PHP10 Iron LMS Hubs 11-1/4" bolt circle. Includes a supplier extended coverage up to 3 years / 350,000 miles for bearings & seals.	170	78
1380270	O	Bendix Air Cam Front Drum Brakes 16.5x6 For use with 14,601 lbs to 22,000 lbs steer axles or FSD16 front drive axles. Includes automatic slack adjusters & outboard mounted brake drums.	105	0
1380470	O	Meritor Wide Track IPO Standard, Front Axle MFS+ 3.5" Drop/MFS 3.74" Drop	0	5
1390540	O	Dust Shields, CAM Brakes, Front Axle	26	4

1391410	O	Gusseted Cam Brackets, Steer Axle	24	0
Rear Axle & Equipment				
1513170	S	Dana Spicer S23-170 23,000 lb Laser factory axle alignment to improve handling & reduce tire wear. Magnetic rear axle oil drain plug captures & holds any metal fragments in drive axle lube to extend service life. Parking brakes on all drive axles for optimal performance. Cognis EMGARD® FE 75W-90 synthetic axle lube provides over 1% fuel economy improvement. Reduces wear & extends maintenance intervals, resulting in increased uptime. Provides improved fluid flow to protect components in extreme cold conditions & withstand the stress from high temperatures, extending component life.	0	0
1616230	S	PHP10 Iron LMS Hubs 11-1/4" bolt circle. Includes a supplier extended coverage up to 3 years / 350,000 miles for bearings & seals.	0	0
1631310	S	Standard Stroke Parking Brakes Drive Axle(s). Not for use on U.S. or Canada Tractors, other than Car Carriers.	0	0
1660000	O	Dust Shields For Cam Brakes, Drive Axle(s)	30	15
1680490	O	Gusseted Cam Brackets, Drive Axle(s)	24	2
1680500	S	SBM Valve Full trucks require a spring brake modulation (SBM) system for emergency braking application. This system requires an SBM valve and a relay valve with spring brakes on the rear axles. The SBM valve allows the foot valve to operate the rear axle spring brakes if a failure exists in the rear air system.	0	0
1680950	S	Stability System Not Selected or Not Available	0	0
1682430	S	Anti-Lock Braking System (ABS) 4S4M ABS-6. Includes air braking system.	0	0
1684200	S	Synthetic Axle Lubricant All Axles Peterbilt heavy duty models include Fuel Efficient Cognis EMGARD FE75W-90 which provides customers performance advantages over current synthetic lubricants with reduced gear wear and extended maintenance intervals, resulting in increased uptime. In additi	0	0
1686348	S	Single Drive Axle (Model 348)	0	0
1687010	S	Bendix Air Cam Rear Drum Brakes 16.5x7 Includes Automatic Slack Adjusters & Outboard Mounted Brake Drums.	0	0
1706140	O	Ratio 6.14 Rear Axle	0	0
1811210	S	Peterbilt Air Trac 23,000 lb Light Weight	0	0
1920385	O	Air Springs, Internal Bumpers Air Trac / Air Leaf suspensions	52	0
1922260	O	Dash Mtd Dump Switch With Indicator Light For suspension	33	2
Engine & Equipment				
2074405	O	PACCAR PX-9 330@2000 GOV@2200 1000@1400 Productivity (2017 Emissions) Includes alum flywheel housing, cruise control, and J1939 provisions (provides an interface point for the Electronic Service Analysis-ESA and other PACCAR approved diagnostic tools). Chevron Delo LE SAE 10W30 engine oil is specially formulated for new low emissions engines. Magnetic engine oil drain plug captures and holds any metal fragments in engine oil to extend service life. N21320 N205 155..Standard Maximum Speed Limit [LSL] N21330 N207 0....Expiration Distance N21340 P005 120..Hard Maximum Speed Limit N21350 P001 64...Maximum Accelerator Pedal Vehicle Speed N21370 P059 64...Maximum Cruise Speed N21400 N203 252..Reserve Speed Function Reset Distance N21410 N202 0....Maximum Cycle Distance N21420 N206 10...Maximum Active Distance N21430 N201 0....Reserve Speed Limit Offset N21440 P015 NO...Engine Protection Shutdown	2,867	0

		N21450 P026 NO...Gear Down Protection		
		N21460 P046 1400.Max PTO Speed		
		N21470 P062 NO...Cruise Control Auto Resume		
		N21480 P068 NO...Auto Engine Brake in Cruise		
		N21500 N209 0....Expiration Distance		
		N21510 P520 YES..Enable Idle Shutdown Park Brake Set		
		N21520 P030 5....Timer Setting		
		N21530 P233 YES..Enable Impending Shutdown Warning		
		N21540 P234 60...Timer For Impending Shutdown Warning		
		N21550 P516 35...Engine Load Threshold		
		N21570 P031 NO...Idle Shutdown Manual Overrule		
		N21590 P230 YES..Enable Hot Ambient Automatic Overrule		
		N21610 P172 40...Low Ambient Temperature Threshold		
		N21620 P173 60...Intermediate Ambient Temperature Threshold		
		N21630 P171 80...High Ambient Temperature Threshold		
2091310	O	Engine Idle Shutdown Timer Disabled	0	0
2091315	O	Enable EIST Ambient Temp Overrule	0	0
2091372	O	Eff EIST NA Expiration Miles	0	0
2091640	O	Effective VSL Setting NA	0	0
2140010	O	Belly Pan	187	35
2140220	O	CARB Engine Idling Compliance DECLINED By Dealer/Customer	0	0
2513060	S	PACCAR 160 Amp Alternator, Brushed	0	0
2522050	S	PACCAR 12V Starter	0	0
2538030	S	2 PACCAR Premium 12V Starting Batteries 2000 CCA Threaded stud type terminal. Stranded copper battery cables are double aught (00) or larger to reduce resistance.	0	0
2539410	O	Battery Jumper Terminal Mounted Under Hood LH Frame Rail. Not available with PX-7 engines.	101	4
2539740	O	Kissling Battery Disconnect Switch Mounted on battery box	188	3
2621000	O	2-Speed Fan Clutch For Frequent Start/Stops	344	0
2723210	S	18.7 CFM Air Compressor N/A X15. Furnished on engine. Teflon lined stainless steel braided compressor discharge line.	0	0
2922780	O	Spin-On Fuel Filter/Water Separator, 12V Heated Frame Mounted. In addition to the fuel filter supplied with the engine. Includes fuel water separator on Models 330, 337, and 348.	79	0
3010400	O	Engine Protection Shutdown Includes oil pressure, oil temperature, coolant temperature, and intake manifold temperature.	5	0
3114270	S	High Efficiency Cooling System Cooling module is a combination of steel and aluminum components, with aluminum connections to maximize performance and cooling capability. Silicone radiator & heater hoses enhance value, durability, & reliability. Constant tension band clamps reduce leaks. ClimaTech extended life coolant extends maintenance intervals which reduces maintenance costs. Anti-freeze effective to -30 degrees F helps protect the engine. Low coolant level sensor warns of low coolant condition to prevent engine damage. Radiator Size by Model: 587: 1330 sq in, 579/367 FEPTO 1325 sq in, 567/365/367: 1440 sq in, 384/386: 1301 sq in, 365 FEPTO: 1184 sq in, 389/367 HH: 1669 sq in, 348: 1000 sq in, 320: 1242 sq in.	0	0
3211120	S	Radial Seal, Dry Type Air Cleaner, Frontal Air Intake. Molded rubber air intake connections with lined stainless steel clamps seal to prevent contaminants in air intake.	0	0
3365270	O	Exhaust Single RH Side Of Cab DPF/SCR RH Under Cab (2017).	256	29
3381770	O	Curved Tip Standpipe(s)	42	0
3387610	O	18in Ht, 5in Dia Chrome, Clear Coat Standpipe(s)	358	-2

Transmission & Equipment

4052110	O	Allison 3000 RDS-P Transmission, Gen 5 Rugged Duty Series. Includes Rear Transmission Support except on MX engines, TranSynd Automatic Transmission Fluid, and Water Oil Heat Exchange. Also includes features that monitor the transmission fluid, filter and clutch condition. Will display percent life remaining for the transmission fluid, filter and clutches on the shift selector. This information may be displayed using the Mode and Up and Down buttons. A wrench icon will also be included to indicate when the transmission fluid, filter or clutches need servicing. (Suited for vehicles operating on/off highway and/or requiring PTO operation) Forward Ratios: 1st-3.49, 2nd-1.86, 3rd-1.41, 4th-1.00, 5th-0.75, 6th-0.65 / Reverse Ratios: DR-(5.03)	10,027	110
4210080	S	1710 HD Driveline, 1 Midship Bearing	0	0
4250650	O	LH PTO Access Dipstick Tube Routing,Allison Trans	0	0
4250720	O	Allison FuelSense Not Desired	0	0
4256640	O	Allison 6-Speed Configuration, Close Ratio Gears 3000 Series Transmissions	0	0
4256920	O	Dash Mounted Push Button Shifter	619	0
Air & Trailer Equipment				
4510330	O	Bendix AD-IS EP Air Dryer with Heater And Coalescing Filter; Extended Purge	168	0
4520420	O	Pull Cords All Air Tanks	5	0
4540420	S	Nylon Chassis Hose	0	0
4543340	O	Aluminum Painted Air Tanks All air tanks are aluminum with painted finish except when Code 4543330 Polish Aluminum Air Tanks is also selected (then exposed air tanks outside the frame rails will be polished aluminum). Peterbilt will determine the optimal size and location of required air tanks. Narratives requesting a specific air tank size or location will not be accepted for factory installation. See ECAT to determine number or location of air tanks installed.	226	-45
Tires & Wheels				
5068590	O	FF: BR 20ply 315/80R22.5 M860A Diameter = 42.8 inches; SLR = 19.9 inches	514	92
5169310	O	RR: BR 16ply 11R22.5 M799 Diameter = 42.0 inches; SLR = 19.5 inches	462	36
5190004	O	Code-rear Tire Qty 04	0	0
5220530	O	FF: Alcoa 89U647 22.5X9.00 Clean Buff Finish Aluminum, Ultra ONE wheels with MagnaForce alloy.	490	-26
5320270	O	RR: Alcoa Ultra7 22.5X8.25 Clean Buff Finish Aluminum	718	-120
5390004	O	Code-rear Rim Qty 04	0	0
Fuel Tanks				
5554100	O	26in Aluminum 70 Gallon Fuel Tank LH U/C Includes steps for cab access. Paddle handle filler cap with threadless filler neck. Top draw fuel plumbing reduces chance of introducing air into the fuel system during low fuel level conditions due to the central placement of fuel pickup tube. Wire braid fuel lines increase durability & reduce potential for leaks.	199	11
5602070	O	Location LH U/C 70 Gallon	0	0
5652890	O	DEF Tank Mounted LH BOC Models 210, 220 and 320 mounted LH cab fender.	0	0
5652990	O	Standard DEF To Fuel Ratio 2:1 Or Greater	0	0
5655019	S	DEF Tank Small	0	0
Battery Box & Bumper				
6010780	O	Aluminum Space Saver Battery Box RH BOC Battery Access From Side	167	-84
6040550	S	Aftertreatment RH U/C Alum Non-Slip Cab Entry	0	0

Step. DPF/SCR for diesel engines, catalyst for natural gas engines. On Models 579 specifying chassis fairings, the box will be aerodynamic.

6121060	O	Steel Bumper Swept Back Painted Black, FEPTO only With two tow pin holes and step plates on top of bumper.	395	90
Cab & Equipment				
6510110	S	Alum Cab 108in BBC Metton Hood w/Bright Crown Includes view window RH door and convex mirror over RH door.	0	0
6540120	O	Severe Service Cab Package #1 Includes Aluminum side skins, aluminum rear skin, steel windshield mask, steel firewall, and steel front floor sheet on all cabs, and additional reinforcement structure on the back wall of the day cab.	119	39
6540160	O	Thermal Insulation Package in Cab Includes thick, closed-cell foam in floor, special mylar-faced foam in walls and roof structure.	19	2
6800360	O	Rubber Fender Lips 2 Inch Wide	94	8
6911700	S	Peterbilt UltraRide Driver Seat	0	0
6921700	S	Peterbilt UltraRide Passenger Seat	0	0
6930500	O	Drivers Armrest - RH Only Required in Model 587 with Evolution LX seats. Optional with Evolution ST and Rolltek Seats.	35	2
6930590	O	Passenger Armrest - LH only Required with Evolution LX seats, optional with Evolution ST Seats.	35	2
6930800	O	Black Seat Color ipo Standard Color	0	0
6939400	S	Air Ride Driver	0	0
6939420	S	High Back Driver	0	0
6939470	S	Vinyl Driver	0	0
6939510	S	Non-Air Ride Passenger	0	0
6939520	S	High Back Passenger	0	0
6939570	S	Vinyl Passenger	0	0
7001520	O	Adjustable Steering Column - Tilt/Telescope	115	11
7001620	S	Steering Wheel with Peterbilt Logo Steering Wheel with embossed Peterbilt logo over horn button.	0	0
7036120	S	Interior Grey/Black Includes rugged charcoal instrument panels, glare-resistant gray dash, black bezels on gauges, (2) power ports, monochromatic molded door pads with durable in-mold color, gray molded back wall, 18 inch 4-spoke soft-touch steering wheel, soft-touch steering column cover, power lift passenger window, extruded rubber floor covering, header-mounted dome light, foot well lighting, integrated "dead pedal", (4) inside entry grab handles, (2) inside sunvisors, (2) coat hooks, (2) cup holders and map bin in dash.	0	0
7210430	O	Extended Rear Window ipo Std Window-Day Cab The extended rear window protrudes two inches more than the standard conventional rear cab window. Take this into consideration when determining your loadspace.	68	0
7210540	S	Day Cab Rear Window	0	0
7230060	S	One Piece Curved Windshield	0	0
7322010	S	Combo Fresh Air Heater/Air Conditioner With radiator mounted condenser, dedicated side window defrosters, Bi-Level Heater/Defroster Controls, 54,500 BTU/HR, and silicone heater hoses.	0	0
7560100	O	Mirrors SSTL Each Side Heated and Motorized with Switch on Door. Right Click on option to See Picture in Product Portfolio.	368	2
7560850	O	(2) Convex 8 Inch SS Mirror Center mounted under mirror bracket. If rear view mirrors are heated, the convex mirrors will be heated. Option includes dual door stops.	209	4
7564110	O	Power Package Includes power door locks and power windows.	313	0

7610020	O	(1) Air Horn 15in Painted Mounted under cab.	155	8
7725710	O	Standard Speaker Package For Cab (2) Speakers	117	4
7725715	O	ConcertClass Without CD, Includes BT Phone and Audio, AM/FM, WB, USB and MP3.	323	10
7748140	O	CB Terminals/Wiring Mtd Under Header	33	0
7850210	O	Plug-In Auto Reset Circuit Breaker in place of fuses in junction box.	40	0
7851480	S	Peterbilt Electric Windshield Wipers With Intermittent Feature.	0	0
8011400	O	Main Transmission Oil Temperature Gauge Located in Driver Information Display	12	0
8021380	S	Air Restriction Indicator Mounted on air cleaner or intake piping.	0	0
8071870	S	Main Instrumentation Panel, Graphics Display Includes speedometer with tripodometer, tachometer with hourmeter and outside air temperature display, voltmeter, engine oil pressure, engine coolant temperature, fuel level, primary and secondary air pressure gauges. Includes standard warning light package: high water temperature, low oil pressure, and low air pressure warning lights w/audible alarms, high beam, turn signal, low fuel, parking brake, and ice warning indicators; seat belt reminder; rocker switches with long-life LED indicators; multi-function turn stalk with flash-to-pass feature (night mode flashes headlights and marker lights; day mode flashes headlights only), intermittent windshield wiper and headlamp beam control. Hydraulic braked trucks do not include air pressure gauges.	0	0
8111110	S	Headlights Composite Fender Mounted Integral Park, Turn, and Side Marker	0	0
8120980	S	(5) Marker Lights, Aero LED Light Emitting Diodes	0	0

Paint

8530770	S	(1) Color Axalta Two Stage - Cab/Hood Base Coat/Clear Coat N85020 A - L0135EY YELLOW N85400 HOOD TOP L0135EY YELLOW N85500 CAB ROOF L0135EY YELLOW N85200 FRAME N0001EA BLACK N85700 BUMPER N0001EA BLACK N85300 FENDER L0135EY YELLOW	0	0
---------	---	---	---	---

Miscellaneous

9409800	O	2017 EPA Emissions Engine Warranty Only	0	0
9409843	O	Peterbilt NJPA Program Code	0	0
9409960	O	Presentation Created Using Featured Spec For Model	0	0

Total Adjusted Price (W/O Freight & Warranty & Surcharges)	\$127,286
Freight Charge	\$2,200
Options Not Subject to Discount	\$0
Surcharges Not subject to Discount	\$0
Total Weight	11582

Prices and Specifications Subject to Change Without Notice.

Unpublished options may require review/approval.
Dimensional and performance data for unpublished options may vary from that displayed in PROSPECTOR.

Printed:	5/15/2017 12:47:51 PM	Complete	Model Number:	Model 348
Effective Date:	Jan 1, 2017		Quote/DTPO/CO:	Q84612360
Prepared by:	Rick M Michalowski		Version Number:	34.20

Prepared for:
Barry Wickersheim
Village of Lakewood
6570 Higgins Rd
Crystal Lake, IL 60014-6628
Phone: 815-459-3025

Prepared by:
Duane Schaefer
TRANSCHICAGO TRUCK
GROUP
776 N. YORK ROAD
ELMHURST, IL 60126
Phone: 630-279-0600 ext 609
Mobile:
E-Mail:
duaneschaefer@transchicago.com

A proposal for
Village of Lakewood
SET-BACK
CUSTOMER DRAFT # 1

Prepared by
TRANSCHICAGO TRUCK GROUP
Duane Schaefer

May 15, 2017

Western Star 4700SB

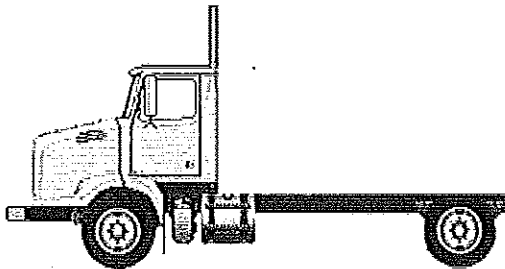

Components shown may not reflect all spec'd options and are not to scale

Application Version 9.2.209
Data Version PRL-16T.003
SB 4700 ISL 102CA 17 May



05/15/2017 3:28 PM

Page 1 of 23

Western Star reserves the right to change specifications, prices, and weights, without notice.

Prepared for:
 Barry Wickersheim
 Village of Lakewood
 6570 Higgins Rd
 Crystal Lake, IL 60014-6628
 Phone: 815-459-3025

Prepared by:
 Duane Schaefer
 TRANSCHICAGO TRUCK
 GROUP
 776 N. YORK ROAD
 ELMHURST, IL 60126
 Phone: 630-279-0600 ext 609
 Mobile:
 E-Mail:
 duaneschaefer@transchicago.com

S P E C I F I C A T I O N P R O P O S A L

Description
Price Level WESTERN STAR 4700 PRL-16T (EFF:04/25/17)
Data Version SPECPRO21 DATA RELEASE VER 003
Vehicle Configuration 4700 SET-BACK FRONT AXLE CHASSIS 2018 MODEL YEAR SPECIFIED SET BACK AXLE - TRUCK STRAIGHT TRUCK PROVISION LH PRIMARY STEERING LOCATION
General Service TRUCK CONFIGURATION DOMICILED, USA 50 STATES (INCLUDING CALIFORNIA AND CARB OPT-IN STATES) UTILITY/REPAIR/MAINTENANCE SERVICE GOVERNMENT BUSINESS SEGMENT DIRT/SAND/ROCK COMMODITY TERRAIN/DUTY: 100% (ALL) OF THE TIME, IN TRANSIT, IS SPENT ON PAVED ROADS MAXIMUM 8% EXPECTED GRADE SMOOTH CONCRETE OR ASPHALT PAVEMENT - MOST SEVERE IN-TRANSIT (BETWEEN SITES) ROAD SURFACE WESTERN STAR VOCATIONAL WARRANTY EXPECTED FRONT AXLE(S) LOAD : 20000.0 lbs EXPECTED REAR DRIVE AXLE(S) LOAD : 23000.0 lbs EXPECTED GROSS VEHICLE WEIGHT CAPACITY : 43000.0 lbs
Truck Service

Application Version 9.2.209
 Data Version PRL-16T.003
 SB 4700 ISL 102CA 17 May



05/15/2017 3:28 PM

Page 2 of 23

Western Star reserves the right to change specifications, prices, and weights, without notice.

Prepared for:
Barry Wickersheim
Village of Lakewood
6570 Higgins Rd
Crystal Lake, IL 60014-6628
Phone: 815-459-3025

Prepared by:
Duane Schaefer
TRANSCHICAGO TRUCK
GROUP
776 N. YORK ROAD
ELMHURST, IL 60126
Phone: 630-279-0600 ext 609
Mobile:
E-Mail:
duaneschaefer@transchicago.com

Description

FRONT PLOW/END DUMP BODY
EXPECTED TRUCK BODY LENGTH : 12.0 ft

Engine

CUM L9 330 HP @ 2000 RPM, 2200 GOV RPM,
1000 LB/FT @ 1400 RPM

Electronic Parameters

75 MPH ROAD SPEED LIMIT
CRUISE CONTROL SPEED LIMIT SAME AS ROAD
SPEED LIMIT
PTO MODE BRAKE OVERRIDE - SERVICE
BRAKE APPLIED
PTO MODE CANCEL VEHICLE SPEED - 5 MPH
PTO GOVERNOR RAMP RATE - 250 RPM PER
SECOND
PTO MINIMUM RPM - 700
REGEN INHIBIT SPEED THRESHOLD - 5 MPH

Engine Equipment

2016 ONBOARD DIAGNOSTICS/2010
EPA/CARB/FINAL GHG17 CONFIGURATION
2008 CARB EMISSION CERTIFICATION - CLEAN
IDLE (INCLUDES 6X4 INCH LABEL ON LOWER
FORWARD CORNER OF DRIVER DOOR)
NO 2013 ENGINE ESCALATOR
STANDARD OIL PAN
OIL FILL AND DIPSTICK LOCATED FOR
ENHANCED SERVICEABILITY
ONE PIECE VALVE COVER
SIDE OF HOOD AIR INTAKE WITH FIREWALL
MOUNTED DONALDSON AIR CLEANER WITH
SAFETY ELEMENT AND INSIDE/OUTSIDE AIR
WITH SNOW DOOR
DR 12V 160 AMP 28-SI QUADRAMOUNT PAD
ALTERNATOR WITH REMOTE BATTERY VOLT
SENSE
(3) ALLIANCE ABSORBED GLASS MAT MODEL
7A31, GROUP 31, 12 VOLT MAINTENANCE FREE
2190 CCA THREADED STUD BATTERIES
PASSENGER SEAT BATTERY BOX VENTED TO
OUTSIDE OF CAB
BATTERY BOX MOUNTED UNDER PASSENGER
SEAT



Prepared for:
Barry Wickersheim
Village of Lakewood
6570 Higgins Rd
Crystal Lake, IL 60014-6628
Phone: 815-459-3025

Prepared by:
Duane Schaefer
TRANSCHICAGO TRUCK
GROUP
776 N. YORK ROAD
ELMHURST, IL 60126
Phone: 630-279-0600 ext 609
Mobile:
E-Mail:
duaneschaefer@transchicago.com

Description

WIRE GROUND RETURN FOR BATTERY CABLES
WITH ADDITIONAL FRAME GROUND RETURN
PLASTIC BATTERY BOX COVER
POSITIVE LOAD DISCONNECT WITH CAB
MOUNTED CONTROL SWITCH MOUNTED
OUTBOARD DRIVER SEAT
POSITIVE AND NEGATIVE POSTS FOR
JUMPSTART LOCATED ON FRAME NEXT TO
STARTER
CUMMINS TURBOCHARGED 18.7 CFM AIR
COMPRESSOR WITH INTERNAL SAFETY VALVE
AIR COMPRESSOR DISCHARGE LINE
ELECTRONIC ENGINE INTEGRAL WARNING AND
DERATE PROTECTION SYSTEM
NO RETARDER
RH OUTBOARD UNDER STEP MOUNTED
HORIZONTAL AFTERTREATMENT SYSTEM
ASSEMBLY WITH RH B-PILLAR MOUNTED
VERTICAL TAILPIPE
ENGINE AFTERTREATMENT DEVICE,
AUTOMATIC OVER THE ROAD REGENERATION
AND DASH MOUNTED REGENERATION
REQUEST SWITCH
10 FOOT 00 INCH (120 INCH+0/-5.9 INCH)
EXHAUST SYSTEM HEIGHT
STANDARD CURVE BRIGHT UPPER STACK(S)
RH CURVED VERTICAL TAILPIPE B-PILLAR
MOUNTED ROUTED FROM STEP
13 GALLON DIESEL EXHAUST FLUID TANK
100 PERCENT DIESEL EXHAUST FLUID FILL
STANDARD DIESEL EXHAUST FLUID PUMP
MOUNTING
NON-POLISHED ALUMINUM DIESEL EXHAUST
FLUID TANK COVER
LH MEDIUM DUTY STANDARD DIESEL EXHAUST
FLUID TANK LOCATION
STAINLESS STEEL AFTERTREATMENT
DEVICE/MUFFLER/TAILOUTLET SHIELD
HORTON DRIVEMASTER ADVANTAGE ON/OFF
FAN DRIVE
AUTOMATIC FAN CONTROL WITHOUT DASH
SWITCH, NON ENGINE MOUNTED
CUMMINS SPIN ON FUEL FILTER
COMBINATION FULL FLOW/BYPASS OIL FILTER

Application Version 9.2.209
Data Version PRL-16T.003
SB 4700 ISL 102CA 17 May



05/15/2017 3:28 PM

Page 4 of 23

Prepared for:
Barry Wickersheim
Village of Lakewood
6570 Higgins Rd
Crystal Lake, IL 60014-6628
Phone: 815-459-3025

Prepared by:
Duane Schaefer
TRANSCHICAGO TRUCK
GROUP
776 N. YORK ROAD
ELMHURST, IL 60126
Phone: 630-279-0600 ext 609
Mobile:
E-Mail:
duaneschaefer@transchicago.com

Description

PENRAY NEED RELEASE WATER FILTER
1300 SQUARE INCH ALUMINUM RADIATOR
MOUNTING FOR FIREWALL MOUNTED SURGE
TANK
ANTIFREEZE TO -34F, ETHYLENE GLYCOL PRE-
CHARGED SCA HEAVY DUTY COOLANT
GATES BLUE STRIPE COOLANT HOSES OR
EQUIVALENT
CONSTANT TENSION HOSE CLAMPS FOR
COOLANT HOSES
RADIATOR DRAIN VALVE
NO RADIATOR/OIL PAN GUARD
PHILLIPS-TEMRO 1000 WATT/115 VOLT BLOCK
HEATER
NO OIL PREHEATER
CHROME ENGINE HEATER RECEPTACLE
MOUNTED UNDER LH DOOR WITH CURRENT
SENSOR LIGHT
ALUMINUM FLYWHEEL HOUSING
ELECTRIC GRID AIR INTAKE WARMER
DELCO 12V 38MT HD STARTER WITH
INTEGRATED MAGNETIC SWITCH

Transmission

ALLISON 3500 RDS AUTOMATIC TRANSMISSION
WITH PTO PROVISION

Transmission Equipment

ALLISON VOCATIONAL PACKAGE 223 -
AVAILABLE ON 3000/4000 PRODUCT FAMILIES
WITH VOCATIONAL MODELS RDS, HS, MH AND
TRV
ALLISON VOCATIONAL RATING FOR ON/OFF
HIGHWAY APPLICATIONS AVAILABLE WITH ALL
PRODUCT FAMILIES
PRIMARY MODE GEARS, LOWEST GEAR 1,
START GEAR 1, HIGHEST GEAR 6, AVAILABLE
FOR 3000/4000 PRODUCT FAMILIES ONLY
SECONDARY MODE GEARS, LOWEST GEAR 1,
START GEAR 1, HIGHEST GEAR 6, AVAILABLE
FOR 3000/4000 PRODUCT FAMILIES ONLY
S5 PERFORMANCE LIMITING PRIMARY SHIFT
SCHEDULE, AVAILABLE FOR 3000/4000
PRODUCT FAMILIES ONLY



Prepared for:
Barry Wickersheim
Village of Lakewood
6570 Higgins Rd
Crystal Lake, IL 60014-6628
Phone: 815-459-3025

Prepared by:
Duane Schaefer
TRANSCHICAGO TRUCK
GROUP
776 N. YORK ROAD
ELMHURST, IL 60126
Phone: 630-279-0600 ext 609
Mobile:
E-Mail:
duaneschaefer@transchicago.com

Description

S5 PREFORMANCE LIMITING SECONDARY
SHIFT SCHEDULE, AVAILABLE FOR 3000/4000
PRODUCT FAMILIES ONLY
2200 RPM PRIMARY MODE SHIFT SPEED
2200 RPM SECONDARY MODE SHIFT SPEED
DISABLE - LOAD BASED SHIFT SCHEDULE,
DISABLE - VEHICLE ACCELERATION CONTROL
BODY LIGHTING INTERFACE BLUNT CUT
WIRING WITH FUSE PANEL WIRE MOUNTED
BETWEEN DRIVER AND PASSENGER SEATS
WITH ADDITIONAL 150 AMP SERVICE
ELECTRONIC TRANSMISSION CUSTOMER
ACCESS CONNECTOR, BLUNT CUT, MOUNTED
BETWEEN DRIVER AND PASSENGER SEATS
(2) CUSTOMER INSTALLED CHELSEA 277
SERIES PTO'S
PTO MOUNTING, LH AND RH SIDES OF MAIN
TRANSMISSION
MAGNETIC PLUGS, ENGINE DRAIN,
TRANSMISSION DRAIN, AXLE(S) FILL AND
DRAIN
PUSH BUTTON ELECTRONIC SHIFT CONTROL,
DASH MOUNTED
TRANSMISSION PROGNOSTICS - ENABLED 2013
WATER TO OIL TRANSMISSION COOLER, IN
RADIATOR END TANK
TRANSMISSION OIL CHECK AND FILL WITH
ELECTRONIC OIL LEVEL CHECK
SYNTHETIC TRANSMISSION FLUID (TES-295
COMPLIANT)

Front Axle and Equipment

DETROIT DA-F-20.0-5 20,000# FL1 71.0 KPI/3.74
DROP SINGLE FRONT AXLE
MERITOR 16.5X6 Q+ CAST SPIDER CAM FRONT
BRAKES, DOUBLE ANCHOR, FABRICATED
SHOES
NON-ASBESTOS FRONT BRAKE LINING
CONMET CAST IRON FRONT BRAKE DRUMS
FRONT OIL SEALS
VENTED FRONT HUB CAPS WITH WINDOW,
CENTER AND SIDE PLUGS - OIL
STANDARD SPINDLE NUTS FOR ALL AXLES

Application Version 9.2.209
Data Version PRL-16T.003
SB 4700 ISL 102CA 17 May



05/15/2017 3:28 PM

Page 6 of 23

Prepared for:
Barry Wickersheim
Village of Lakewood
6570 Higgins Rd
Crystal Lake, IL 60014-6628
Phone: 815-459-3025

Prepared by:
Duane Schaefer
TRANSCHICAGO TRUCK
GROUP
776 N. YORK ROAD
ELMHURST, IL 60126
Phone: 630-279-0600 ext 609
Mobile:
E-Mail:
duaneschaefer@transchicago.com

Description

HALDEX AUTOMATIC FRONT SLACK
ADJUSTERS WITH STAINLESS STEEL CLEVIS
PINS
STANDARD KING PIN BUSHINGS
TRW THP-60 POWER STEERING WITH RCH45
AUXILIARY GEAR
POWER STEERING PUMP
4 QUART POWER STEERING RESERVOIR
OIL/AIR POWER STEERING COOLER
SYNTHETIC 75W-90 FRONT AXLE LUBE

Front Suspension

23,000# FLAT LEAF FRONT SUSPENSION
THREADED SPRING PINS AND BUSHINGS -
FRONT SUSPENSION
FRONT SHOCK ABSORBERS

Rear Axle and Equipment

RS-23-160 23,000# R-SERIES SINGLE REAR
AXLE
5.38 REAR AXLE RATIO
IRON REAR AXLE CARRIER WITH STANDARD
AXLE HOUSING
MXL 17N MERITOR EXTENDED LUBE MAIN
DRIVELINE WITH FULL ROUND YOKES
DRIVER CONTROLLED TRACTION
DIFFERENTIAL - SINGLE REAR AXLE
(1) DRIVER CONTROLLED DIFFERENTIAL LOCK
REAR VALVE FOR SINGLE DRIVE AXLE
INDICATOR LIGHT FOR EACH DRIVER
CONTROLLED TRACTION DEVICE SWITCH
MERITOR 16.5X7 Q+ CAST SPIDER CAM REAR
BRAKES, DOUBLE ANCHOR, FABRICATED
SHOES
NON-ASBESTOS REAR BRAKE LINING
BRAKE CAMS AND CHAMBERS ON FORWARD
SIDE OF DRIVE AXLE(S) WITH AUXILIARY
SUPPORT BRACKETS
CONMET CAST IRON REAR BRAKE DRUMS
REAR OIL SEALS
BENDIX EVERSURE LONGSTROKE 1-DRIVE
AXLE SPRING PARKING CHAMBERS



Prepared for:
Barry Wickersheim
Village of Lakewood
6570 Higgins Rd
Crystal Lake, IL 60014-6628
Phone: 815-459-3025

Prepared by:
Duane Schaefer
TRANSCHICAGO TRUCK
GROUP
776 N. YORK ROAD
ELMHURST, IL 60126
Phone: 630-279-0600 ext 609
Mobile:
E-Mail:
duaneschaefer@transchicago.com

Description

HALDEX AUTOMATIC REAR SLACK ADJUSTERS
WITH STAINLESS STEEL CLEVIS PINS
SYNTHETIC 75W-90 REAR AXLE LUBE

Rear Suspension

AIRLINER 23,000# REAR SUSPENSION WITH
CHAIN CLEARANCE
AIRLINER HIGH POSITION RIDE HEIGHT
STANDARD AXLE SEATS IN AXLE CLAMP
GROUP
MANUAL DUMP VALVE FOR AIR SUSPENSION
WITH GAUGE
INDICATOR LIGHT FOR EACH REAR
SUSPENSION CONTROL SWITCH
DUAL AIR REAR SUSPENSION LEVELING
VALVES
TRANSVERSE CONTROL RODS
HEAVY DUTY SUSPENSION OPTION -
23,000#, 46,000#, 69,000# AIRLINER
SUSPENSIONS
REAR SHOCK ABSORBERS - ONE AXLE (AIR
RIDE SUSPENSION)

Brake System

WABCO 4S/4M ABS WITH TRACTION CONTROL
REINFORCED NYLON, FABRIC BRAID AND WIRE
BRAID CHASSIS AIR LINES
FIBER BRAID PARKING BRAKE HOSE
STANDARD BRAKE SYSTEM VALVES
RELAY VALVE WITH 5-8 PSI CRACK PRESSURE,
NO REAR PROPORTIONING VALVE
WABCO SS-1200 PLUS AIR DRYER WITH
INTEGRAL AIR GOVERNOR AND HEATER
WABCO OIL COALESCING FILTER FOR AIR
DRYER
AIR DRYER MOUNTED INBOARD ON LH RAIL
STEEL AIR BRAKE RESERVOIRS MOUNTED
INSIDE RAIL WITH NO OUTBOARD BRACKETS
CLEAR FRAME RAILS FROM BACK OF CAB TO
FRONT REAR SUSPENSION BRACKET, BOTH
RAILS OUTBOARD
BW DV-2 AUTO DRAIN VALVE WITH HEATER ON
WET TANK, DV-2 WITHOUT HEATER ON ALL
OTHER TANKS



Prepared for:
Barry Wickersheim
Village of Lakewood
6570 Higgins Rd
Crystal Lake, IL 60014-6628
Phone: 815-459-3025

Prepared by:
Duane Schaefer
TRANSCHICAGO TRUCK
GROUP
776 N. YORK ROAD
ELMHURST, IL 60126
Phone: 630-279-0600 ext 609
Mobile:
E-Mail:
duaneschaefer@transchicago.com

Description

Wheelbase & Frame

4200MM (165 INCH) WHEELBASE
7/16X3-9/16X11-1/8 INCH STEEL FRAME
(11.11MMX282.6MM/0.437X11.13 INCH) 120KSI
PARTIAL INNER FRAME REINFORCEMENT AT
FRONT SUSPENSION
BODY COMPANY INSTALLED ADDITIONAL
FRONT FRAME REINFORCEMENT FOR SNOW
PLOW
1525MM (60 INCH) REAR FRAME OVERHANG
FRAME OVERHANG RANGE: 51 INCH TO 60
INCH
12 INCH INTEGRAL FRONT FRAME EXTENSION
CALC'D BACK OF CAB TO REAR SUSP C/L (CA) :
101.69 in
CALCULATED EFFECTIVE BACK OF CAB TO
REAR SUSPENSION C/L (CA) : 98.69 in
CALC'D FRAME LENGTH - OVERALL : 282.6
CALC'D SPACE AVAILABLE FOR DECKPLATE :
101.69 in
CALCULATED FRAME SPACE LH SIDE : 71.8 in
CALCULATED FRAME SPACE RH SIDE : 132.9 in
SQUARE END OF FRAME
STANDARD WEIGHT ENGINE CROSSMEMBER
STANDARD CROSSMEMBER BACK OF
TRANSMISSION
STANDARD MIDSHIP #1 CROSSMEMBER(S)
STANDARD REARMOST CROSSMEMBER
HEAVY DUTY SUSPENSION CROSSMEMBER
STANDARD WEIGHT REAR SUSPENSION
CROSSMEMBER

Chassis Equipment

14 INCH PAINTED STEEL BUMPER
BUMPER MOUNTING FOR SINGLE LICENSE
PLATE
FRONT ANTI-SPRAY CAB MOUNTED MUDFLAPS
HUCK-SPIN ROUND COLLAR CHASSIS
FASTENERS
EXTERIOR HARNESSES WRAPPED IN CONDUIT



Prepared for:
Barry Wickersheim
Village of Lakewood
6570 Higgins Rd
Crystal Lake, IL 60014-6628
Phone: 815-459-3025

Prepared by:
Duane Schaefer
TRANSCHICAGO TRUCK
GROUP
776 N. YORK ROAD
ELMHURST, IL 60126
Phone: 630-279-0600 ext 609
Mobile:
E-Mail:
duaneschaefer@transchicago.com

Description

D15-16004-000 CENTER PUNCH TO MARK
CENTERLINE OF REAR SUSPENSION ON
FRAME WEB

Fuel Tanks

60 GALLON/227 LITER ALUMINUM FUEL TANK -
LH
25 INCH DIAMETER FUEL TANK(S)
PLAIN ALUMINUM/PAINTED STEEL
FUEL/HYDRAULIC TANK(S) WITH POLISHED
STAINLESS STEEL BANDS
FUEL TANK(S) FORWARD
PLAIN STEP FINISH
FUEL TANK CAP(S)
DAVCO 245 FUEL/WATER SEPARATOR WITH 12
VOLT HEAT AND WATER IN FUEL SENSOR
EQUIFLO INBOARD FUEL SYSTEM
HIGH TEMPERATURE REINFORCED NYLON
FUEL LINE
INSULATION FOR FUEL LINES
NO FUEL COOLER

Tires

CONTINENTAL CITY SERVICE HA3 315/80R22.5
20 PLY RADIAL FRONT TIRES
CONTINENTAL HDR2 11R22.5 14 PLY RADIAL
REAR TIRES

Hubs

CONMET PRESET PLUS PREMIUM IRON FRONT
HUBS
CONMET PRESET PLUS PREMIUM IRON REAR
HUBS

Wheels

ACCURIDE 41012 22.5X9.00 10-HUB PILOT 3.12
INSET 10-HAND ALUMINUM DISC FRONT
WHEELS
ACCURIDE 41644 ACCU-LITE 22.5X8.25 10-HUB
PILOT ALUMINUM DISC REAR WHEELS
FRONT WHEEL MOUNTING NUTS
REAR WHEEL MOUNTING NUTS
NYLON WHEEL GUARDS FRONT AND REAR ALL
INTERFACES



Prepared for:
Barry Wickersheim
Village of Lakewood
6570 Higgins Rd
Crystal Lake, IL 60014-6628
Phone: 815-459-3025

Prepared by:
Duane Schaefer
TRANSCHICAGO TRUCK
GROUP
776 N. YORK ROAD
ELMHURST, IL 60126
Phone: 630-279-0600 ext 609
Mobile:
E-Mail:
duaneschaefer@transchicago.com

Description
Cab Exterior
110 INCH BBC STEEL CONVENTIONAL CAB WESTERN STAR PAINTED ALUMINUM CAB SKIRT AIR CAB MOUNTS WITH CHECK VALVE NONREMOVABLE BUGSCREEN MOUNTED BEHIND GRILLE FRONT FENDERS 2 INCH FENDER EXTENSIONS LH AND RH EXTERIOR GRAB HANDLES WITH RUBBER INSERTS AND RH INTERIOR GRAB HANDLE MOUNTED TO A POST STATIONARY BRIGHT FINISH GRILLE CHROME HOOD MOUNTED AIR INTAKE GRILLE GALVANEALD STEEL SEVERE SERVICE CAB FIBERGLASS HOOD WITH ACCESS HATCHES DUAL ROUND AIR HORNS, SINGLE BASE, MOUNTED UNDER CAB SINGLE ELECTRIC HORN DOORS AND IGNITION KEYED THE SAME (3 KEYS) REAR LICENSE PLATE MOUNT END OF FRAME SINGLE RECTANGULAR SEALED BEAM HEADLIGHTS WITH BRIGHT BEZELS LED MARKER LAMPS WIRING AND SWITCH FOR CUSTOMER FURNISHED SNOW PLOW LAMPS WITH SINGLE CONNECTION AT LH FORWARD INTEGRAL STOP/TAIL/BACKUP LIGHTS STANDARD FRONT TURN SIGNAL LAMPS DUAL MEKRA AERO BRIGHT FINISH HEATED DUAL AXIS 1-PIECE MOTORIZED MIRRORS WITH LIGHTS, LH AND RH REMOTE AND INTEGRAL CONVEX MIRRORS CAB MOUNTED MIRRORS 102 INCH EQUIPMENT WIDTH DUAL MEKRA BRIGHT FINISH HEATED CONVEX MIRRORS WITH MANUAL ADJUSTMENT AND DUAL AXIS FOR 1-PIECE PRIMARY MIRRORS RH DOWN VIEW MIRROR STANDARD SIDE/REAR REFLECTORS



Prepared for:
Barry Wickersheim
Village of Lakewood
6570 Higgins Rd
Crystal Lake, IL 60014-6628
Phone: 815-459-3025

Prepared by:
Duane Schaefer
TRANSCHICAGO TRUCK
GROUP
776 N. YORK ROAD
ELMHURST, IL 60126
Phone: 630-279-0600 ext 609
Mobile:
E-Mail:
duaneschaefer@transchicago.com

Description

ELECTRIC DOOR LOCKS, MECHANICAL KEY
TUMBLER
STAINLESS STEEL EXTERIOR SUN VISOR
17.5X35 INCH TINTED REAR WINDOW
TINTED DOOR GLASS
RH AND LH ELECTRIC POWERED WINDOWS
LOWER RH DOOR WINDOW WITH FRESNEL
LENS
2-PIECE TINTED CURVED GASKET MOUNTED
HEATED WINDSHIELD
2 GALLON WINDSHIELD WASHER RESERVOIR
WITHOUT FLUID LEVEL INDICATOR, MOUNTED
UNDER CAB, WITH REMOTE FILL

Cab Interior

GRAY VINYL BASE INTERIOR
BLACK HARD TRIM
PREMIUM LEFT HAND DOOR TRIM WITH
CHERRY ACCENT
PREMIUM RIGHT HAND DOOR TRIM WITH
CHERRY ACCENT
BLACK MATS WITH DOUBLE INSULATION
DASH MOUNTED ASH TRAY AND LIGHTER,
DRIVER SIDE
FORWARD ROOF MOUNTED CONSOLE
PASSENGER SIDE WING DASH MOUNTED
GLOVE BOX WITH LOCKING DOOR
14"X7.75" DOCUMENT POUCH MOUNTED ON
BACK WALL BETWEEN SEATS
LH AND RH DOOR MAP POCKETS
(2) COAT HOOKS ON BACKWALL OF CAB
BLACK SOFT TOUCH WING DASH WITH DRIVER
SIDE COSMETIC UNDER DASH COVER
STANDARD WIRING
5 LB. FIRE EXTINGUISHER
HEATER, DEFROSTER AND AIR CONDITIONER
WITH CONSTANT OUTLET TEMPERATURE
CONTROL
HVAC DUCTING WITH DUST/ODOR MAIN FRESH
AIR FILTER AND OUTSIDE PRE-FILTER
MAIN HVAC CONTROLS WITH RECIRCULATION
SWITCH



Prepared for:
Barry Wickersheim
Village of Lakewood
6570 Higgins Rd
Crystal Lake, IL 60014-6628
Phone: 815-459-3025

Prepared by:
Duane Schaefer
TRANSCHICAGO TRUCK
GROUP
776 N. YORK ROAD
ELMHURST, IL 60126
Phone: 630-279-0600 ext 609
Mobile:
E-Mail:
duaneschaefer@transchicago.com

Description

STANDARD HEATER PLUMBING WITH BALL SHUTOFF VALVES
DENSO HEAVY DUTY AIR CONDITIONER COMPRESSOR
RADIATOR MOUNTED AIR CONDITIONER CONDENSER
BINARY CONTROL, R-134A
ADDITIONAL CAB SIDEWALL INSULATION
AUTOMATIC SELF-RESET CIRCUIT BREAKER IN MAIN DASH POWER DISTRIBUTION BOX AND CIRCUIT BREAKER/FUSE IN AUXILIARY POWER DISTRIBUTION BOXES
DOOR ACTIVATED DOME LIGHT, UNDER DASH LIGHT WITH LH AND RH DOOR MOUNTED COURTESY LIGHTS AND LH AND RH READING LIGHTS
LH AND RH ELECTRIC DOOR LOCKS
(2) 12 VOLT POWER RECEPTACLES MOUNTED IN DASH
TRIANGULAR REFLECTORS KIT WITHOUT FLARES SHIPPED LOOSE IN CAB
PREMIUM HIGH BACK AIR SUSPENSION DRIVER SEAT WITH 3 CHAMBER AIR LUMBAR, INTEGRATED CUSHION EXTENSION, FORWARD AND REAR CUSHION TILT, ADJUSTABLE SHOCK ABSORBER
BATTERY BOX MID BACK NON SUSPENSION PASSENGER SEAT
DUAL DRIVER SEAT ARMRESTS, NO PASSENGER SEAT ARMRESTS
BLACK CORDURA PLUS CLOTH DRIVER SEAT COVER
BLACK CORDURA PLUS CLOTH PASSENGER SEAT COVER
3 POINT HIGH VISIBILITY ORANGE RETRACTOR DRIVER AND PASSENGER SEAT BELTS
ADJUSTABLE TILT AND TELESCOPING STEERING COLUMN
2-SPOKE 18 INCH (450MM) BLACK LEATHER WRAPPED STEERING WHEEL
DRIVER AND PASSENGER INTERIOR SUN VISORS

Instruments & Controls

NON-ADJUSTABLE SUSPENDED PEDALS

Application Version 9.2.209
Data Version PRL-16T.003
SB 4700 ISL 102CA 17 May



05/15/2017 3:28 PM

Page 13 of 23

Prepared for:
Barry Wickersheim
Village of Lakewood
6570 Higgins Rd
Crystal Lake, IL 60014-6628
Phone: 815-459-3025

Prepared by:
Duane Schaefer
TRANSCHICAGO TRUCK
GROUP
776 N. YORK ROAD
ELMHURST, IL 60126
Phone: 630-279-0600 ext 609
Mobile:
E-Mail:
duaneschaefer@transchicago.com

Description

STAR GAUGES WITH BRIGHT BEZELS
FIGURED CHERRY WOODGRAIN ULTRA GLOSS
FINISH DRIVER INSTRUMENT PANEL
FIGURED CHERRY WOODGRAIN ULTRA GLOSS
FINISH CENTER INSTRUMENT PANEL
LOW AIR PRESSURE INDICATOR LIGHT AND
AUDIBLE ALARM
2 INCH PRIMARY AND SECONDARY AIR
PRESSURE GAUGES
DASH MOUNTED AIR RESTRICTION INDICATOR
WITH GRADUATIONS
87 DB TO 112 DB SELF-ADJUSTING BACKUP
ALARM
CRUISE CONTROL SWITCHES IN THE CENTER
PANEL
KEY OPERATED IGNITION SWITCH AND
INTEGRAL START POSITION; 4 POSITION
OFF/RUN/START/ACCESSORY
DATASTAR DRIVER DISPLAY IN OVERHEAD
CONSOLE AND WARNING LAMP/LIGHT BAR IN
DASH NON-DATA LINK
HEAVY DUTY ONBOARD DIAGNOSTICS
INTERFACE CONNECTOR LOCATED BELOW LH
DASH
2 INCH ELECTRIC FUEL GAUGE
PROGRAMMABLE RPM CONTROL -
ELECTRONIC ENGINE
ELECTRICAL ENGINE COOLANT TEMPERATURE
GAUGE
2 INCH TRANSMISSION OIL TEMPERATURE
GAUGE
CUSTOMER FURNISHED AND INSTALLED PTO
CONTROLS
ELECTRIC ENGINE OIL PRESSURE GAUGE
TOP OF DASH NAVIGATION PREP WITH POWER
AND GROUND
AM/FM/WB WORLD TUNER RADIO WITH
BLUETOOTH AND USB AND AUXILIARY INPUTS,
J1939
ROOF/OVERHEAD CONSOLE MOUNTED RADIO
(4) RADIO SPEAKERS IN CAB
AM/FM ANTENNA MOUNTED ON LH FRONT A-
PILLAR
NO CB RADIO/PROVISION

Application Version 9.2.209
Data Version PRL-16T.003
SB 4700 ISL 102CA 17 May



05/15/2017 3:28 PM

Page 14 of 23

Prepared for:
Barry Wickersheim
Village of Lakewood
6570 Higgins Rd
Crystal Lake, IL 60014-6628
Phone: 815-459-3025

Prepared by:
Duane Schaefer
TRANSCHICAGO TRUCK
GROUP
776 N. YORK ROAD
ELMHURST, IL 60128
Phone: 630-279-0600 ext 609
Mobile:
E-Mail:
duaneschaefer@transchicago.com

Description

NO CB ANTENNA, BRACKET OR LEAD
ELECTRONIC MPH SPEEDOMETER WITH
SECONDARY KPH SCALE, WITH ODOMETER
STANDARD VEHICLE SPEED SENSOR WITH
ADDITIONAL SIGNAL FOR CUSTOMER USE
LOCATED BETWEEN DRIVER AND PASSENGER
SEATS
ELECTRONIC 3000 RPM TACHOMETER
NO VEHICLE PERFORMANCE MONITOR
NO DETROIT CONNECT SERVICES SELECTED
NO ZONAR SERVICES SELECTED
IGNITION SWITCH CONTROLLED ENGINE STOP
2 INCH VOLTMETER
SINGLE ELECTRIC WINDSHIELD WIPER MOTOR
WITH DELAY AND ARCTIC TYPE BLADES
CAB MARKER LIGHT AND HEADLIGHT SWITCH
WITH SEPARATE SWITCH AND TERMINALS FOR
CUSTOMER FURNISHED SNOW PLOW LIGHTS
AND TURN SIGNALS
ONE VALVE PARKING BRAKE SYSTEM WITH
DASH VALVE CONTROL AUTONEUTRAL AND
WARNING INDICATOR
SELF CANCELING TURN SIGNAL SWITCH WITH
INTEGRAL HEADLAMP DIMMER WITHOUT
BRAKE OVERRIDE
PACIFIC INSIGHT ELECTRONIC FLASHER

Design

PAINT: ONE SOLID COLOR

Color

CAB COLOR A: L6460EB SCHOOL BUS YELLOW
ELITE BC
CAB INTERIOR PAINTED SAME AS CAB COLOR
BLACK, HIGH SOLIDS POLYURETHANE CHASSIS
PAINT
BUMPER PAINTED SAME AS CHASSIS

Certification / Compliance

U.S. FMVSS CERTIFICATION, EXCEPT SALES
CABS AND GLIDER KITS

Secondary Factory Options

NO PDI INSTALLED GRILLE/HOOD TRIM

Application Version 9.2.209
Data Version PRL-16T.003
SB 4700 ISL 102CA 17 May



05/15/2017 3:28 PM

Page 15 of 23

Prepared for:
Barry Wickersheim
Village of Lakewood
6570 Higgins Rd
Crystal Lake, IL 60014-6628
Phone: 815-459-3025

Prepared by:
Duane Schaefer
TRANSHICAGO TRUCK
GROUP
776 N. YORK ROAD
ELMHURST, IL 60126
Phone: 630-279-0600 ext 609
Mobile:
E-Mail:
duaneschaefer@transchicago.com

Description

DEALER HAS BEEN ADVISED OF AND
ACCEPTED RESPONSIBILITY FOR
MODIFICATIONS DUE TO POSSIBLE
PTO/CHASSIS INTERFERENCE

Extended Warranty

CUM 2017 L9: HD1 MD DTY 5 YEARS / 100,000 MILES / 161,000 KM
EXTENDED WARRANTY. FEX APPLIES

CUM 2017 L9: AT3 MD DTY 5 YEARS / 100,000 MILES / 161,000 KM
AFTERTREATMENT. FEX APPLIES



Prepared for:
 Barry Wickersheim
 Village of Lakewood
 6570 Higgins Rd
 Crystal Lake, IL 60014-6628
 Phone: 815-459-3025

Prepared by:
 Duane Schaefer
 TRANSCHICAGO TRUCK
 GROUP
 776 N. YORK ROAD
 ELMHURST, IL 60126
 Phone: 630-279-0600 ext 609
 Mobile:
 E-Mail:
 duaneschaefer@transchicago.com

D I M E N S I O N S

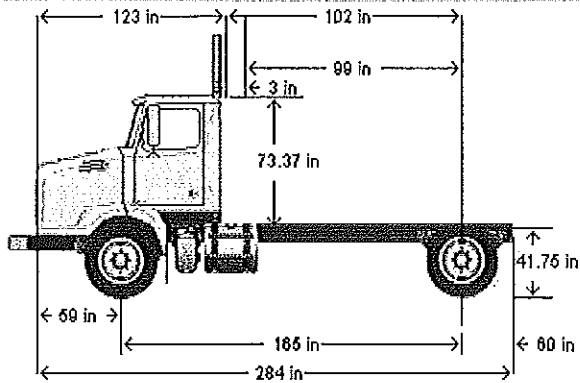

VEHICLE SPECIFICATIONS SUMMARY - DIMENSIONS

Model	4700SB
Wheelbase (545)	4200MM (165 INCH) WHEELBASE
Rear Frame Overhang (552).....	1525MM (60 INCH) REAR FRAME OVERHANG
Fifth Wheel (578).....	NO FIFTH WHEEL
Mounting Location (577)	NO FIFTH WHEEL LOCATION
Maximum Forward Position (in).....	0
Maximum Rearward Position (in)	0
Amount of Slide Travel (in).....	0
Slide Increment (in).....	0
Desired Slide Position (in).....	0.0
Cab Size (829).....	110 INCH BBC STEEL CONVENTIONAL CAB
Sleeper (682).....	NO SLEEPER BOX/SLEEPER/CAB
Exhaust System (016)	RH OUTBOARD UNDER STEP MOUNTED HORIZONTAL AFTERTREATMENT SYSTEM ASSEMBLY WITH RH B-PILLAR MOUNTED VERTICAL TAILPIPE



Prepared for:
 Barry Wickersheim
 Village of Lakewood
 6570 Higgins Rd
 Crystal Lake, IL 60014-6628
 Phone: 815-459-3025

Prepared by:
 Duane Schaefer
 TRANSCHICAGO TRUCK
 GROUP
 776 N. YORK ROAD
 ELMHURST, IL 60126
 Phone: 630-279-0600 ext 609
 Mobile:
 E-Mail:
 duaneschaefer@transchicago.com

TABLE SUMMARY - DIMENSIONS

Dimensions	Inches
Bumper to Back of Cab (BBC)	122.7
Bumper to Centerline of Front Axle (BA)	59.4
Min. Cab to Body Clearance (CB)	3.0
Back of Cab to Centerline of Rear Axle(s) (CA)	101.7
Effective Back of Cab to Centerline of Rear Axle(s) (Effective CA)	98.7
Back of Cab Protrusions (Exhaust/Intake) (CP)	2.0
Back of Cab Protrusions (Side Extenders/Trim Tab) (CP)	0.0
Back of Cab Protrusions (CNG Tank)	0.0
Back of Cab Clearance (CL)	3.0
Back of Cab to End of Frame	161.7
Cab Height (CH)	73.4
Wheelbase (WB)	165.0
Frame Overhang (OH)	60.0
Overall Length (OAL)	284.4
Rear Axle Spacing	0.0
Unladen Frame Height at Centerline of Rear Axle	41.8

Performance calculations are estimates only. If performance calculations are critical, please contact Customer Application Engineering.



Prepared for:
 Barry Wickersheim
 Village of Lakewood
 6570 Higgins Rd
 Crystal Lake, IL 60014-6628
 Phone: 815-459-3025

Prepared by:
 Duane Schaefer
 TRANSSHICAGO TRUCK
 GROUP
 776 N. YORK ROAD
 ELMHURST, IL 60126
 Phone: 630-279-0600 ext 609
 Mobile:
 E-Mail:
 duaneschaefer@transchicago.com

G V W R

VEHICLE SPECIFICATIONS SUMMARY - GVWR

Model	4700SB
Cab Size (829).....	110 INCH BBC STEEL CONVENTIONAL CAB
Expected Front Axle(s) Load (lbs).....	20000.0
Expected Pusher Axle(s) Load (lbs).....	0.0
Expected Rear Axle(s) Load (lbs)	23000.0
Expected Tag Axle(s) Load (lbs).....	0.0
Expected GVW (lbs)	43000
Expected GCW (lbs).....	0.0
Front Axle (400).....	DETROIT DA-F-20.0-5 20,000# FL1 71.0 KPI/3.74 DROP SINGLE FRONT AXLE
Front Suspension (620)	23,000# FLAT LEAF FRONT SUSPENSION
Front Hubs (418)	CONMET PRESET PLUS PREMIUM IRON FRONT HUBS
Front Disc Wheels (502) ..	ACCURIDE 41012 22.5X9.00 10-HUB PILOT 3.12 INSET 10-HAND ALUMINUM DISC FRONT WHEELS
Front Tires (093).....	CONTINENTAL CITY SERVICE HA3 315/80R22.5 20 PLY RADIAL FRONT TIRES
Front Brakes (402).....	MERITOR 16.5X6 Q+ CAST SPIDER CAM FRONT BRAKES, DOUBLE ANCHOR, FABRICATED SHOES
Steering Gear (536).....	TRW THP-60 POWER STEERING WITH RCH45 AUXILIARY GEAR
Rear Axle (420)	RS-23-160 23,000# R-SERIES SINGLE REAR AXLE
Rear Suspension (622).....	AIRLINER 23,000# REAR SUSPENSION WITH CHAIN CLEARANCE
Rear Hubs (450).....	CONMET PRESET PLUS PREMIUM IRON REAR HUBS
Rear Disc Wheels (505).....	ACCURIDE 41644 ACCU-LITE 22.5X8.25 10-HUB PILOT ALUMINUM DISC REAR WHEELS
Rear Tires (094)	CONTINENTAL HDR2 11R22.5 14 PLY RADIAL REAR TIRES
Rear Brakes (423)	MERITOR 16.5X7 Q+ CAST SPIDER CAM REAR BRAKES, DOUBLE ANCHOR, FABRICATED SHOES
Pusher / Tag Axle (443).....	NO PUSHER OR TAG AXLE
Pusher / Tag Suspension (626)	NO PUSHER OR TAG SUSPENSION
Pusher / Tag Hubs (449).....	NO PUSHER OR TAG HUBS
Pusher/Tag Disc Wheels (509)	NO PUSHER/TAG DISC WHEELS
Pusher / Tag Tires (095).....	NO PUSHER/TAG TIRES
Pusher / Tag Brakes (456).....	NO PUSHER/TAG BRAKES



Prepared for:
 Barry Wickersheim
 Village of Lakewood
 6570 Higgins Rd
 Crystal Lake, IL 60014-6628
 Phone: 815-459-3025

Prepared by:
 Duane Schaefer
 TRANSCHICAGO TRUCK
 GROUP
 776 N. YORK ROAD
 ELMHURST, IL 60126
 Phone: 630-279-0600 ext 609
 Mobile:
 E-Mail:
 duaneschaefer@transchicago.com

TABLE SUMMARY - GVWR

	Front	Rear
Axle Component Weight Ratings		
Axes	20000	23000
Suspension	23000	23000
Hubs	23000	26000
Brakes	20000	23000
Wheels	20400	29600
Tires	20000	23360
Power Steering	22000	N/A
GAWR (per axle)	20000	23000
GAWR (per axle system)	20000	23000
Expected Load (per axle system)	20000	23000
Vehicle GVWR Summary		
Calculated GVWR	43000	
Expected GVWR	43000	
All weights displayed in pounds		

Performance calculations are estimates only. If performance calculations are critical, please contact Customer Application Engineering.



Prepared for:
 Barry Wickersheim
 Village of Lakewood
 6570 Higgins Rd
 Crystal Lake, IL 60014-6628
 Phone: 815-459-3025

Prepared by:
 Duane Schaefer
 TRANSCHICAGO TRUCK
 GROUP
 776 N. YORK ROAD
 ELMHURST, IL 60126
 Phone: 630-279-0600 ext 609
 Mobile:
 E-Mail:
 duaneschaefer@transchicago.com

F R A M E R B M

VEHICLE SPECIFICATIONS SUMMARY - FRAME RBM

Wheelbase (545) 4200MM (165 INCH) WHEELBASE
 Frame Rails (546)..... 7/16X3-9/16X11-1/8 INCH STEEL FRAME (11.11MMX282.6MM/0.437X11.13 INCH) 120KSI(546)
 Yield Strength (psi) 120000
 Section Modulus (per rail) (cu in) 21.6
 RBM (per rail) (lbf-in) 2592000
 Inner Frame Reinforcement (547)..... PARTIAL INNER FRAME REINFORCEMENT AT FRONT SUSPENSION
 Outer Frame Reinforcement (548) .. BODY COMPANY INSTALLED ADDITIONAL FRONT FRAME REINFORCEMENT FOR SNOW PLOW

TABLE SUMMARY - FRAME RBM

Item	Description / Value
Wheelbase	4200MM (165 INCH) WHEELBASE
Frame	7/16X3-9/16X11-1/8 INCH STEEL FRAME (11.11MMX282.6MM/0.437X11.13 INCH) 120KSI
Inner Frame Reinforcement	PARTIAL INNER FRAME REINFORCEMENT AT FRONT SUSPENSION
Outer Frame Reinforcement	BODY COMPANY INSTALLED ADDITIONAL FRONT FRAME REINFORCEMENT FOR SNOW PLOW
Yield Strength (psi)	120000
Section Modulus - per rail (cu. in.)	21.60
Frame RBM - per rail (lbf-in)	2592000

Performance calculations are estimates only. If performance calculations are critical, please contact Customer Application Engineering.



Prepared for:
 Barry Wickersheim
 Village of Lakewood
 6570 Higgins Rd
 Crystal Lake, IL 60014-6628
 Phone: 815-459-3025

Prepared by:
 Duane Schaefer
 TRANSSHICAGO TRUCK
 GROUP
 776 N. YORK ROAD
 ELMHURST, IL 60126
 Phone: 630-279-0600 ext 609
 Mobile:
 E-Mail:
 duaneschaefer@transschicago.com

TURNING RADIUS

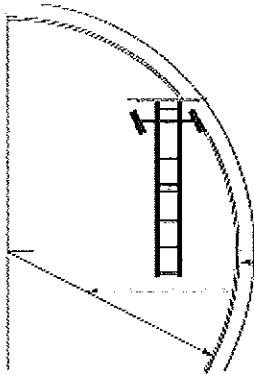

Turning radius graphic and data provided for general estimate purposes only. For specific figures regarding your configuration, please contact your CAE representative.

	Left Turn	Right Turn	Tolerance
Wall to Wall Diameter (ft)	61.2	52.7	+/- 3.0
Curb to Curb Diameter (ft)	54.5	44.9	+/- 3.0
Turning Radius (ft)	26.8	21.9	+/- 1.5

VEHICLE SPECIFICATIONS SUMMARY - TURNING RADIUS

Model 4700SB
 Cab Size (829)..... 110 INCH BBC STEEL CONVENTIONAL CAB
 Wheelbase (545).....4200MM (165 INCH) WHEELBASE
 Front Tires (093)..... CONTINENTAL CITY SERVICE HA3 315/80R22.5 20 PLY RADIAL FRONT TIRES
 Width (in) 12.4
 Front Axle (400)..... DETROIT DA-F-20.0-5 20,000# FL1 71.0 KPI/3.74 DROP SINGLE FRONT AXLE
 Kingpin Intersection (in) 71
 Bumper (556) 14 INCH PAINTED STEEL BUMPER
 Width (in) 97.6
 Bumper Miter to Front Axle (in) 71.401
 Primary Steering Location (003) LH PRIMARY STEERING LOCATION
 Steering Gear (536)..... TRW THP-60 POWER STEERING WITH RCH45 AUXILIARY GEAR
 Dual Steering Gear RCH45
 Ram NONE
 Rear Axle (420) RS-23-160 23,000# R-SERIES SINGLE REAR AXLE
 Axle Spacing (624) NO AXLE SPACING

Performance calculations are estimates only. If performance calculations are critical, please contact Customer Application Engineering.



Prepared for:
 Barry Wickersheim
 Village of Lakewood
 6570 Higgins Rd
 Crystal Lake, IL 60014-6628
 Phone: 815-459-3025

Prepared by:
 Duane Schaefer
 TRANSCHICAGO TRUCK
 GROUP
 776 N. YORK ROAD
 ELMHURST, IL 60126
 Phone: 630-279-0600 ext 609
 Mobile:
 E-Mail:
 duaneschaefer@transchicago.com

Q U O T A T I O N

4700 SET-BACK FRONT AXLE CHASSIS

<p>SET BACK AXLE - TRUCK CUM L9 330 HP @ 2000 RPM, 2200 GOV RPM, 1000 LB/FT @ 1400 RPM ALLISON 3500 RDS AUTOMATIC TRANSMISSION WITH PTO PROVISION RS-23-160 23,000# R-SERIES SINGLE REAR AXLE AIRLINER 23,000# REAR SUSPENSION WITH CHAIN CLEARANCE DETROIT DA-F-20.0-5 20,000# FL1 71.0 KPI/3.74 DROP SINGLE FRONT AXLE 23,000# FLAT LEAF FRONT SUSPENSION</p>	<p>110 INCH BBC STEEL CONVENTIONAL CAB 4200MM (165 INCH) WHEELBASE 7/16X3-9/16X11-1/8 INCH STEEL FRAME (11.11MMX282.6MM/0.437X11.13 INCH) 120KSI 1525MM (60 INCH) REAR FRAME OVERHANG PARTIAL INNER FRAME REINFORCEMENT AT FRONT SUSPENSION BODY COMPANY INSTALLED ADDITIONAL FRONT FRAME REINFORCEMENT FOR SNOW PLOW</p>
---	---

PER UNIT TOTAL

EXTENDED WARRANTY

CUM 2017 L9: HD1 MD DTY 5 YEARS /
 100,000 MILES / 161,000 KM
 EXTENDED WARRANTY. FEX APPLIES

CUM 2017 L9: AT3 MD DTY 5 YEARS /
 100,000 MILES / 161,000 KM
 AFTERTREATMENT. FEX APPLIES

BALANCE DUE	(LOCAL CURRENCY) \$	91,237 \$	91,237
-------------	---------------------	-----------	--------



Memo

To: Honorable President and Board of Trustees
From: Shannon Andrews, Interim Village Manager
CC: Michael Smoron, Village Attorney
Date: May 19, 2017
Re: Proposal for Single Year Audit by Eder, Casella & Co.

Attached please find a proposal from Eder, Casella & Co ("Eder") to perform the Village of Lakewood's audit examination and preparation for the Annual Financial Report for the State of Illinois for the fiscal year ending April 2017.

This is a standard agreement and consistent with those that the Village of Lakewood has entered into with Eder for the past several years. Eder has consistently held their rate flat at \$22,500 for the past three years, until 2016 when the new pension standard (GASB 68) was introduced and billed separately. The current agreement incorporates a 3% increase over the previous contract rate plus the GASB 68 fee, for a total not to exceed of \$24,000.

The continuity provided by Eder will be particularly beneficial during this period of high activity and management transition in the organization. If approved, Eder is prepared to begin the audit as early as June 12.

Staff recommends the Board approve the agreement with Eder, Casella & Co. to perform the Village of Lakewood's audit examination and preparation of the Annual Financial Report for the State of Illinois for fiscal year ending April 30, 2017.



815.344.1300 mchenry
847.382.3366 barrington
www.edercasella.com

June 12, 2017

Board of Trustees and
Ms. Shannon Andrews, Interim Village Manager
Village of Lakewood
2500 Lake Ave.
Lakewood, IL 60014

We are pleased to confirm our understanding of the services we are to provide Village of Lakewood for the year ended April 30, 2017. This letter, and the attached Terms and Conditions Addendum and any other attachments incorporated herein, (collectively, "Agreement"), confirms our understanding of the terms and objectives of our engagement and the nature and limitations of the services we will provide. The engagement between you and our firm will be governed by the terms of this Agreement.

We will audit the financial statements of the governmental activities, the business-type activities, each major fund, and the aggregate remaining fund information, including the related notes to the financial statements, which collectively comprise the basic financial statements of Village of Lakewood as of and for the year ended April 30, 2017. Accounting standards generally accepted in the United States of America provide for certain required supplementary information (RSI), such as management's discussion and analysis (MD&A), to supplement Village of Lakewood's basic financial statements. Such information, although not a part of the basic financial statements, is required by the Governmental Accounting Standards Board who considers it to be an essential part of financial reporting for placing the basic financial statements in an appropriate operational, economic, or historical context. As part of our engagement, we will apply certain limited procedures to Village of Lakewood's RSI in accordance with auditing standards generally accepted in the United States of America. These limited procedures will consist of inquiries of management regarding the methods of preparing the information and comparing the information for consistency with management's responses to our inquiries, the basic financial statements, and other knowledge we obtained during our audit of the basic financial statements. We will not express an opinion or provide any assurance on the information because the limited procedures do not provide us with sufficient evidence to express an opinion or provide any assurance. The following RSI is required by generally accepted accounting principles and will be subjected to certain limited procedures, but will not be audited:

1. Management's discussion and analysis
2. Illinois Municipal Retirement Fund – Schedule of Changes in the Employer's Net Pension Liability and Related Ratios
3. Illinois Municipal Retirement Fund – Schedule of Employer Contribution
4. Schedule of Revenues, Expenditures, and Changes in Fund Balance – Budget and Actual – General Fund
5. Notes to Required Supplementary Information

Audit Objective

The objective of our audit is the expression of opinions as to whether your financial statements are fairly presented, in all material respects, in conformity with generally accepted accounting principles and to report on the fairness of the supplementary information referred to in the second paragraph when considered in relation to the financial statements as a whole. Our audit will be conducted in accordance with auditing standards generally accepted in the United States of America and will include tests of the accounting records and other procedures we consider necessary to enable us to express such opinions. We will issue a written report upon completion of our audit of Village of Lakewood's financial statements. Our report will be addressed to the Board of Trustees of Village of Lakewood. We cannot provide assurance that unmodified opinions will be expressed. Circumstances

eder, caseella & co.

may arise in which it is necessary for us to modify our opinions or add emphasis-of-matter or other-matter paragraphs. If our opinions are other than unmodified, we will discuss the reasons with you in advance. If, for any reason, we are unable to complete the audit or are unable to form or have not formed opinions, we may decline to express opinions or may withdraw from this engagement.

Audit Procedures – General

An audit includes examining, on a test basis, evidence supporting the amounts and disclosures in the financial statements; therefore, our audit will involve judgment about the number of transactions to be examined and the areas to be tested. An audit also includes evaluating the appropriateness of accounting policies used and the reasonableness of significant accounting estimates made by management, as well as evaluating the overall presentation of the financial statements. We will plan and perform the audit to obtain reasonable assurance about whether the financial statements are free of material misstatement, whether from (1) errors, (2) fraudulent financial reporting, (3) misappropriation of assets, or (4) violations of laws or governmental regulations that are attributable to the government or to acts by management or employees acting on behalf of the government.

Because of the inherent limitations of an audit, combined with the inherent limitations of internal control, and because we will not perform a detailed examination of all transactions, there is a risk that material misstatements may exist and not be detected by us, even though the audit is properly planned and performed in accordance with U.S. generally accepted auditing standards. In addition, an audit is not designed to detect immaterial misstatements, or violations of laws or governmental regulations that do not have a direct and material effect on the financial statements. However, we will inform the appropriate level of management of any material errors, fraudulent financial reporting, or misappropriation of assets that comes to our attention. We will also inform the appropriate level of management of any violations of laws or governmental regulations that come to our attention, unless clearly inconsequential. Our responsibility as auditors is limited to the period covered by our audit and does not extend to matters that may arise during any later periods for which we are not engaged as auditors.

Our procedures will include tests of documentary evidence supporting the transactions recorded in the accounts, and may include tests of the physical existence of inventories, and direct confirmation of receivables and certain other assets and liabilities by correspondence with selected individuals, funding sources, creditors, and financial institutions. We will request written representations from your attorneys as part of the engagement, and they may bill you for responding to this inquiry. At the conclusion of our audit, we will require certain written representations from you about the financial statements and related matters.

Audit Procedures – Internal Control

Our audit will include obtaining an understanding of the government and its environment, including internal control, sufficient to assess the risks of material misstatement of the financial statements and to design the nature, timing, and extent of further audit procedures. An audit is not designed to provide assurance on internal control or to identify deficiencies in internal control. However, during the audit, we will communicate to management and those charged with governance internal control related matters that are required to be communicated under AICPA professional standards.

Audit Procedures – Compliance

As part of obtaining reasonable assurance about whether the financial statements are free of material misstatement, we will perform tests of Village of Lakewood's compliance with the provisions of applicable laws, regulations, contracts, and agreements. However, the objective of our audit will not be to provide an opinion on overall compliance and we will not express such an opinion.

Other Services

We will also prepare the financial statements and Annual Financial Report for the State of Illinois of Village of Lakewood in conformity with U.S. generally accepted accounting principles based on information

provided by you. We will perform the services in accordance with applicable professional standards. The other services are limited to the financial statement services previously defined. We, in our sole professional judgment, reserve the right to refuse to perform any procedure or take any action that could be construed as assuming management responsibilities.

Management Responsibilities

Management is responsible for designing, implementing, and maintaining effective internal controls, including monitoring ongoing activities; for the selection and application of accounting principles; and for the preparation and fair presentation of the financial statements in conformity with U.S. generally accepted accounting principles.

Management is also responsible for making all financial records and related information available to us and for the accuracy and completeness of that information. You are also responsible for providing us with (1) access to all information of which you are aware that is relevant to the preparation and fair presentation of the financial statements, (2) additional information that we may request for the purpose of the audit, and (3) unrestricted access to persons within the government from whom we determine it necessary to obtain audit evidence.

Your responsibilities include adjusting the financial statements to correct material misstatements and confirming to us in the management representation letter that the effects of any uncorrected misstatements aggregated by us during the current engagement and pertaining to the latest period presented are immaterial, both individually and in the aggregate, to the financial statements taken as a whole.

You are responsible for the design and implementation of programs and controls to prevent and detect fraud, and for informing us about all known or suspected fraud affecting the government involving (1) management, (2) employees who have significant roles in internal control, and (3) others where the fraud could have a material effect on the financial statements. Your responsibilities include informing us of your knowledge of any allegations of fraud or suspected fraud affecting the government received in communications from employees, former employees, regulators, or others. In addition, you are responsible for identifying and ensuring that the government complies with applicable laws and regulations.

You are responsible for the preparation of the supplementary information in conformity with U.S. generally accepted accounting principles. You agree to include our report on the supplementary information in any document that contains and indicates that we have reported on the supplementary information. You also agree to include the audited financial statements with any presentation of the supplementary information that includes our report thereon or make the audited financial statements readily available to users of the supplementary information no later than the date the supplementary information is issued with our report thereon. Your responsibilities include acknowledging to us in the representation letter that (1) you are responsible for presentation of the supplementary information in accordance with GAAP; (2) you believe the supplementary information, including its form and content, is fairly presented in accordance with GAAP; (3) the methods of measurement or presentation have not changed from those used in the prior period (or, if they have changed, the reasons for such changes); and (4) you have disclosed to us any significant assumptions or interpretations underlying the measurement or presentation of the supplementary information. With regard to using the auditor's report, you understand that you must obtain our prior written consent to reproduce or use our report in bond offering official statements or other documents. With regard to the electronic dissemination of audited financial statements, including financial statements published electronically on your website, you understand that electronic sites are a means to distribute information and, therefore, we are not required to read the information contained in these sites or to consider the consistency of other information in the electronic site with the original document.

You agree to assume all management responsibilities for financial statement preparation services and any other nonattest services we provide; oversee the services by designating an individual, preferably from senior management, with suitable skill, knowledge, or experience; evaluate the adequacy and results of the services; and accept responsibility for them.

Engagement Administration, Fees, and Other

We understand that your employees will prepare all cash or other confirmations we request and will locate any documents selected by us for testing.

We expect to begin our audit on approximately June 12, 2017 and to issue our reports no later than October 6, 2017. John Albanese is the engagement partner and is responsible for supervising the engagement and signing the report or authorizing another individual to sign it.

To ensure that Eder, Casella & Co.'s independence is not impaired under the AICPA Code of Professional Conduct, you agree to inform the engagement partner before entering into any substantive employment discussions with any of our personnel.

In order to reduce our professional staff hours and in consideration of the agreed-upon fee, you have agreed that the general ledger will be in balance by individual fund; the cash is reconciled, on a monthly basis, to the amounts shown on your general ledger; your staff will be available to answer questions, locate misplaced documents and resolve problems as needed; and your filing system will allow for easy retrieval of the documents we request.

During this engagement we may need to refer to selected records of yours and may require a photocopy of these records for our working papers. It is our policy to return all of your original records after our use along with copies of any financial reports and/or tax returns we issue. It is your responsibility to retain your records as you deem appropriate. Our working papers, including any photocopies that we obtain from you, are our property and will be retained by us in accordance with our established record retention policy. A copy of our record retention policy is available upon request. This policy stipulates that, in general, we will retain these working papers, copies of financial reports, and copies of tax returns for a period of seven years. After this period expires, the files will be disposed of.

We have agreed that our fee for the audit examination (which includes the GASB 68 fee that has been listed separately in past years) and preparation of the Annual Financial Report for the State of Illinois will not exceed \$24,000.00. The actual fee may vary from the amount shown due to variations in conditions or additional audit procedures requested by the State of Illinois or other agencies. Fees for such additional services would be billed at our usual hourly rates. We would inform you if we were experiencing any difficulty which would cause any increase in the base fee. All services will be billed to you monthly, payable on receipt. Amounts unpaid after 60 days will be charged late fees at a rate of 1% per month in addition to costs of collection.

We appreciate the opportunity to be of service to Village of Lakewood and believe this letter accurately summarizes the significant terms of our engagement. In the event you provide us with some of the information necessary to perform these services, the commencement of our services constitutes your acceptance of the terms of this letter, even if this engagement agreement is not signed. If you have any questions, please let us know. If you agree with the terms of our engagement as described in this letter, please sign below and return this letter to us.

Very truly yours,

Eder, Casella & Co.

EDER, CASELLA & CO.

Certified Public Accountants

This letter correctly sets forth the understanding of Village of Lakewood.

By: _____

Title: _____

Date: _____

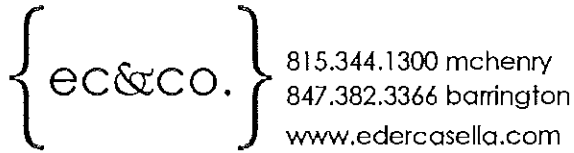

TERMS AND CONDITIONS ADDENDUM

Billing and Payment Terms

Payment is due within 30 days of the date on the billing statement. If payment is not received by the due date, you will be assessed interest charges of 1.5% per month on the unpaid balance.

We reserve the right to suspend or terminate our work for non-payment of fees. If our work is suspended or terminated, you agree that we will not be responsible for your failure to meet governmental and other deadlines, for any penalties or interest that may be assessed against you resulting from your failure to meet such deadlines, and for any other damages (including but not limited to consequential, indirect, lost profits, or punitive damages) incurred as a result of the suspension or termination of our services.

Electronic Data Communication and Storage

In the interest of facilitating our services to you, we may send data over the Internet, or store electronic data via computer software applications hosted remotely on the Internet or clouds. Your confidential electronic data may be transmitted or stored using these methods. We may use third party service providers to store or transmit this data, such as providers of tax return preparation software. In using these data communication and storage methods, our firm employs measures designed to maintain data security. We use reasonable efforts to keep such communications and data access secure in accordance with our obligations under applicable laws, regulations, and professional standards. We require our third party vendors to do the same.

You recognize and accept that we have no control over the unauthorized interception or breach of any communications or data once it has been sent or has been subject to unauthorized access, notwithstanding all reasonable security measures employed by us or our third party vendors. You consent to our use of these electronic devices and applications and submission of confidential client information to third party service providers during this engagement.

Client Portals

To enhance our services to you, we will use Client Portals, a collaborative, virtual workspace in a protected, online environment. Client Portals allow for real-time collaboration across geographic boundaries and time zones and allows Eder, Casella & Co. and you to share data, engagement information, knowledge, and deliverables in a protected environment. In order to use Client Portals, you agree to be bound by the terms, conditions and limitations of the client portal agreement located on our website.

You agree that Eder, Casella & Co. has no responsibility for the activities of Client Portals and agree to indemnify and hold Eder, Casella & Co. harmless with respect to any and all claims arising from or related to the operation of Client Portals. While Client Portals backs up your files to a third party server, we recommend that you also maintain your own backup files of these records.

Records Management

Record Retention and Ownership

We will return all your original records and documents provided to us at the conclusion of the engagement. Your records are the primary records for your operations and comprise the backup and support for your work product. Our copies of your records and documents are not a substitute for your own records and do not mitigate your record retention obligations under any applicable laws or regulations.

eder, casella & co.

Workpapers and other documents created by us are our property and will remain in our control. Copies are not to be distributed without our prior written consent. Our workpapers will be maintained by us in accordance with our firm's record retention policy and any applicable legal and regulatory requirements. A copy of our record retention policy is available upon request.

Our firm destroys workpaper files after a period of seven years. Catastrophic events or physical deterioration may result in damage to or destruction of our firm's records, causing the records to be unavailable before the expiration of the retention period as stated in our record retention policy.

Working Paper Access Requests by Regulators and Others

State, federal and foreign regulators may request access to or copies of certain workpapers pursuant to applicable legal or regulatory requirements. Requests may also come in the form of peer review, ethics investigations or in the sale of the accounting practice. If requested, access to such workpapers will be provided under the supervision of firm personnel. Regulators may request copies of selected workpapers to distribute the copies or information contained therein to others, including other governmental agencies.

If we receive a request for copies of selected workpapers, provided that we are not prohibited from doing so by law or regulation, we agree to inform you of such request as soon as practicable. You may, within the time permitted for our firm to respond to any request, initiate such legal action as you deem appropriate at your own expense to limit the disclosure of information. If you take no action within the time permitted for us to respond, or if your action does not result in a judicial order protecting us from supplying requested information, we may construe your inaction or failure as consent to comply with the request.

Summons or Subpoenas

All information you provide to us in connection with this engagement will be maintained by us on a strictly confidential basis. If we receive a summons or subpoena which our legal counsel determines requires us to produce documents from this engagement or testify about this engagement and we are not prohibited from doing so by law or regulation, we agree to inform you of such summons or subpoena as soon as practical.

You may, within the time permitted for our firm to respond to any request, initiate such legal action as you deem appropriate at your own expense to attempt to limit discovery. If you take no action within the time permitted for us to respond, or if your action does not result in a judicial order protecting us from supplying requested information, we may construe your inaction or failure as consent to comply with the request. If we are not a party to the proceeding in which the information is sought, you agree to reimburse us for our professional time and expenses, as well as the fees and expenses of our counsel, incurred in responding to such requests.

Brokerage or Investment Advisory Statements

If you provide our firm with copies of brokerage (or investment advisory) statements and/or read-only access to your accounts, we will use the information solely for the purpose described in the scope of engagement section. We will rely on the accuracy of the information provided in the statements and will not undertake any action to verify this information. We will not monitor transactions, investment activity, provide investment advice, or supervise the actions of the entity or individuals entering into transactions or investment activities on your behalf. We recommend you receive and carefully review all statements upon receipt, and direct any questions regarding account activity to your banker, broker or investment advisor.

Other Income, Losses and Expenses

If you realized income, loss or expense from a business or supplemental income or loss, the reporting requirements of federal and state income tax authorities apply to such income, loss or expense. You are responsible for complying with all applicable laws and regulations pertaining to such operations, including the classification of workers as employees or independent contractors and related payroll tax and withholding requirements.

Accountant – Client Privilege

Internal Revenue Code §7525, Confidentiality privileges related to taxpayer communication, provides a limited confidentiality privilege covering certain tax advice embodied in taxpayer communications with federally authorized tax practitioners in certain limited situations.

This privilege is limited in several important respects. For example, this privilege does not apply to your records, which you are required to retain in support of your tax return. In addition, the privilege does not apply to state tax issues, state tax proceedings, private civil litigation proceedings, or criminal proceedings. While we will cooperate with you with respect to the privilege, asserting the privilege is your responsibility. Inadvertent disclosure of otherwise privileged information may result in a waiver of the privilege. Please contact us immediately if you have any questions or need further information about this matter.

Management Responsibilities

While Eder, Casella & Co. can provide assistance, you are responsible for management decisions and functions, and for designating an individual with suitable skill, knowledge or experience to oversee any services Eder, Casella & Co. provides. You are responsible for evaluating the adequacy and results of the services performed and accepting responsibility for such services. You are ultimately responsible for establishing and maintaining internal controls, including monitoring ongoing activities.

Conflicts of Interest

If we, in our sole discretion, believe a conflict has arisen affecting our ability to deliver services to you in accordance with either the ethical standards of our firm or the ethical standards of our profession, we may be required to suspend or terminate our services without issuing our work product.

Alternative Dispute Resolution

If a dispute arises out of or relates to this engagement letter including the scope of services engagement contained herein, or the breach thereof, and if the dispute cannot be settled through negotiation, the parties agree first to try to settle the dispute by mediation administered by the American Arbitration Association ("AAA") under the Professional Accounting and Related Services Dispute Resolution Rules before resorting to arbitration, litigation, or some other dispute resolution procedure. The mediator will be selected by agreement of the parties. If the parties cannot agree on a mediator, a mediator shall be designated by the AAA. Any mediator so designated must be acceptable to all parties. The mediation will be conducted in Illinois. The mediation will be treated as a settlement discussion and, therefore, will be confidential. The mediator may not testify for either party in any later proceeding related to the dispute. No recording or transcript shall be made of the mediation proceedings. The costs of any mediation proceedings shall be shared equally by all parties. Any costs for legal representation shall be borne by the hiring party.

Loss Limitation and Indemnification

Eder, Casella & Co.'s liability for all claims, damages, and costs arising from this engagement is limited to only the total amount of fees paid by you to Eder, Casella & Co. for services rendered for the period under this agreement.

You agree to hold Eder, Casella & Co. harmless from any and all claims which arise from knowing misrepresentations to Eder, Casella & Co. by your management, or the intentional withholding or concealment of information from Eder, Casella & Co. by your management. You also agree to indemnify Eder, Casella & Co. for any claims made against Eder, Casella & Co. by third parties which arise from any of these actions by your management. The provisions of this paragraph shall apply regardless of the nature of the claim.

You agree to indemnify, defend, and hold harmless Eder, Casella & Co. and any of its partners, principals, shareholders, officers, directors, members, employees, agents or assigns with respect to any and all claims arising from this engagement, regardless of the nature of the claim, and including the negligence of any party, excepting claims arising from the gross negligence or intentional acts of the firm.

Designation of Venue and Jurisdiction

We agree that the courts of the State of Illinois have jurisdiction over the parties. We also agree that the laws of the State of Illinois shall govern all such disputes.

Statute of Limitations

You agree that any claim arising out of this engagement letter shall be commenced within one (1) year of the delivery of the work product to you, regardless of any longer period of time for commencing such claim as may be set by law. A claim is understood to be a demand for money or services, the service of a suit, or the institution of arbitration proceedings against Eder, Casella & Co.

Termination and Withdrawal

We reserve the right to withdraw from the engagement without completing services for any reason, including, but not limited to, your failure to comply with the terms of this engagement letter or as we determine professional standards require.

Assignment

All parties acknowledge and agree that the terms and conditions of this engagement letter shall be binding upon and inure to the parties' successors and assigns, subject to applicable laws and regulations.

Severability

If any portion of this agreement is deemed invalid or unenforceable, said finding shall not operate to invalidate the remainder of the terms set forth in this engagement letter.

Entire Agreement

This engagement letter, including the Terms and Conditions Addendum and any other attachments, encompasses the entire agreement of the parties and supersedes all previous understandings and agreements between the parties, whether oral or written. Any modification to the terms of this engagement letter must be made in writing and signed by both parties.

Client Manager:

Jason Fluhr
 jfluhr@baxterwoodman.com
 815-444-3222

Project Status Report Issued On: 5/19/2017

Project Title/Job	Project Manager	Completion Date	Tasks Completed This Period	Tasks Pending This Period	Items Waiting On Client	Status Date
Cambria Subdivision - Lots 3-6 Utility Modification Job Number: [060883.91]	John Tierney (262) 763-7834 jtierney@baxterwoodman.com	10/1/2020	Approved Lot 5 building permit in coordination with the Utility Modification Plans.	Assist Village with utility relocation inspection where needed.		5/18/2017
Lake Ave STP Construction Services Job Number: [140645.60]	Craig Mitchell (815) 459-1260 cmitchell@baxterwoodman.com	9/29/2017	5/18/17-striping placed 5/4, signs 5/5 5/4/17-asphalt work completed 4/18/17. Leveling binder installed on Lake Avenue. Patching and binder course completed on Pheasant. Milling complete on side streets as of 4/21	landscaping and punch list.	Nothing at this time.	5/18/2017
Haligus Elevated Tank Repainting Job Number: [161183.00]	Ray Koenig (708) 478-2090 rkoenig@baxterwoodman.com	7/1/2017	Contracts have been sent to Jetco for execution.	Contract execution, preconstruction meeting	Waiting for decision on contract document format for agreement between Lakewood and Jetco, Ltd. from Village.	5/18/2017
2017 NPDES PHase II Permit Assistance Job Number: [170083.90]	Joel Krause (815) 459-1260 jkrause@baxterwoodman.com	6/1/2017	Draft annual report	Completion of Final Annual Report	Information for report and review of draft	5/18/2017